



# KU 100-120W BUC

## User Manual



**RevGo Global Inc.**

12007 Sunrise Valley Dr., #450

Reston, VA 20191 USA

Tel: +1(703)348-9933

E-mail: [Sales@RevGoGroup.com](mailto:Sales@RevGoGroup.com)

Website: [www.RevgoGlobal.com](http://www.RevgoGlobal.com)

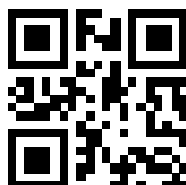

## Safety Precautions



### WARNING !

All repair works must be performed by manufacturer personnel, and any unauthorized repair will void warranty status.



### DANGEROUS HIGH POWER RF !

The equipment's RF Out port emits a high power RF energy causing severe body injury.

Ensure that the RF Out port is connected to an antenna system or a high power load prior to powering and operating the unit.



### HIGH SPEED FANS AND DO NOT TOUCH !

Do not touch the FAN leaves before they slow down.



### HOT SURFACE AND DO NOT TOUCH !

The equipment's surface temperature is high during operation. Do not touch or move it by hand.

- Please use tape with high thermos ability, UV protection to wrap the IF connector and RF connector to make sure connection water proof.
- Please install this equipment in a ventilated environment to ensure the heat could be dissipated in time.
- Please ensure this equipment grounding well to avoid damage from lightning surge while performing outside.

## Packing list

No.	Qty.	Description
1.	1 unit	Qty(1), Ku BUC
2.	1 set	Annexes: Qty(1), O-ring Qty(4), Hexagon socket combination screw M4×14 Qty(1), Hexagon Wrench Key (M4) Qty(1), PT06E-12-14S(424) @ M&C Qty(1), ACS06E10SL-3S(548) @ Power Supply
3.	1 sheet	Test report
4.	1 sheet	User manual

## Maintenance and Warranty Service

### Maintenance

- Inspect this equipment performance status every 6 months.
- Check the connectors whether is corroded and loosened, or not.

### Warranty Service

- During warranty time, if this equipment fails due to defects in materials or workmanship, at its sole discretion, manufacturer will repair or replace the defective parts free of charge.
- This warranty will be voided, freeing manufacturer from any liability of obligation to the Purchaser with respect to the product in following situations:
  - (1) Incorrect transportation, storage, installation, and operation.
  - (2) Some irresistible natural accidents.
  - (3) Unsuitable apply environment.
  - (4) Sabotage cases.
  - (5) Any unauthorized repair work.
- Prior to send the failed equipment back, please provide the product number, serial number, and failed details to manufacturer, and get approved by manufacturer.

## Exterior and Structure

### Interfaces Instructions

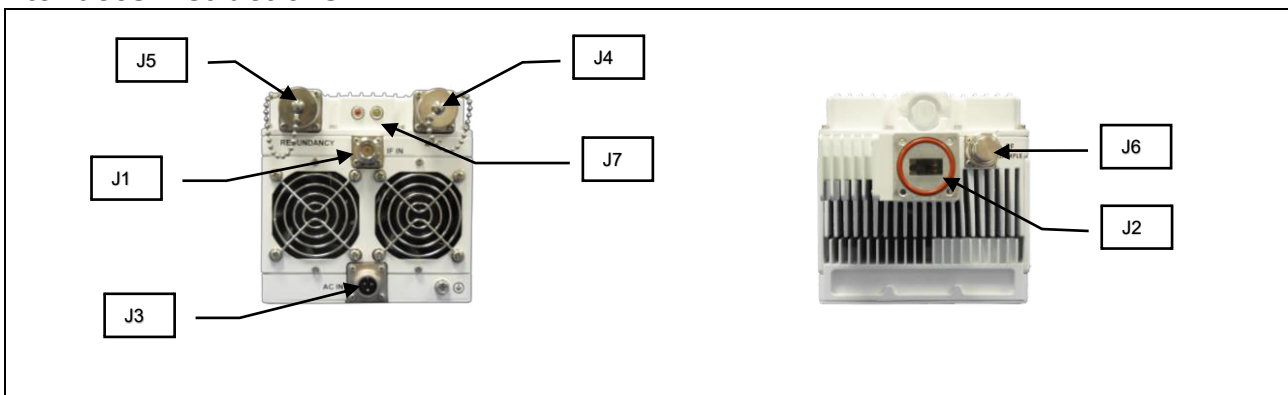

No.	Interfaces	Specifications	Parameters
J1	IF Input Connector	N-type Connector	<b>S:</b> 950~1450 MHz, <b>E:</b> 950~1700 MHz
J2	RF Output Connector	WR75-G	<b>S:</b> 14.00~14.50 GHz, <b>E:</b> 13.75~14.50 GHz
J3	Power Connector	ACS02E10SL-3P	85 ~ 265 VAC, 47~63Hz
J4	M&C Connector	PT02E-12-14P	RS-485、RS-232、Ethernet(Http)
J5	Redundant M&C Connector	PT02E-12-14S	RS-232
J6	RF sampling port	N-type Connector	The output signal level is about: Pout-50 dB
J7	LED Indicators	Green x1 Red x1	Green LED on : Running normally Green LED flashing: BUC mute Red LED flashing: PLL alarm Red LED on : Other alarm

## RF sampling port

- When testing or debugging equipment, the RF signal can be extracted through this port. The output power of the RF signal is about: Pout-50dBm, so in practical work, please connect a load of about 1W (Watt) to this port.

## Redundant M&C port

- This M&C port is only used when two BUCs constitute a 1+1 redundant system. If customers choose to purchase 1 + 1 redundant system, the redundant communication cables will be distributed when the products leave the factory.

## Structure Diagram (Unit: in[mm])

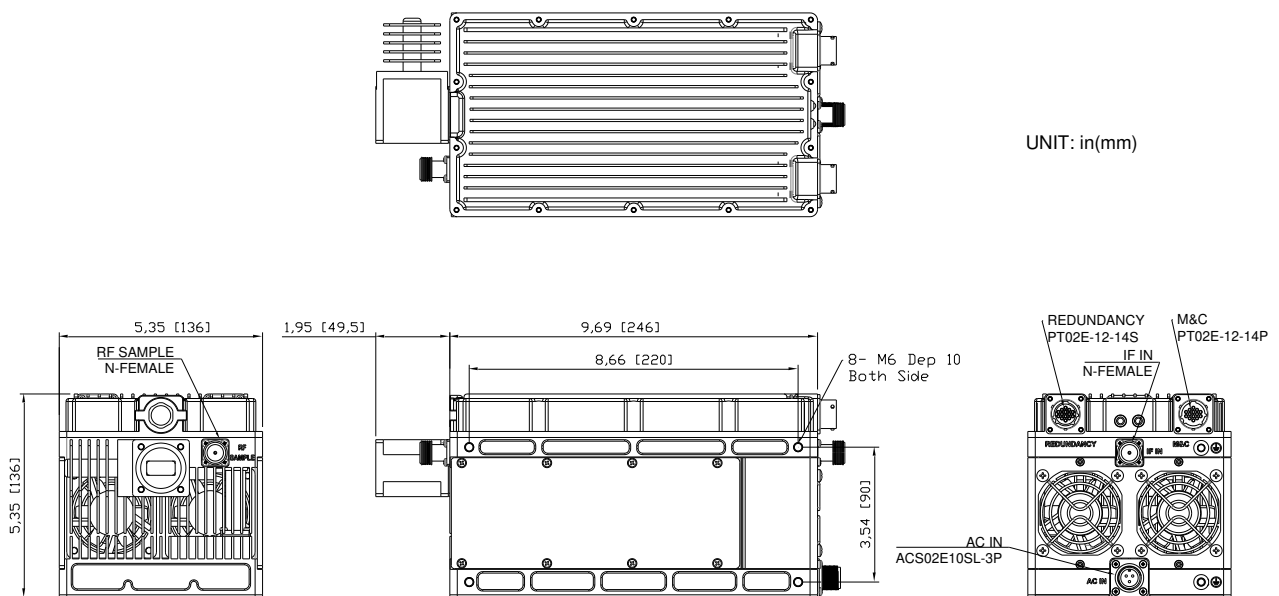

## Preparations

- Inspect the type and quantity of accessories reference the packing list.
- Inspect the exterior and connectors there shall not be obvious defects.
- Prepare a suitable independent power supply: Please select the corresponding power supply mode according to the model instructions of the purchased products.
- Prepare for this unit with four cables of Coaxial Cable, Power Cable, M&C Signal Cable, Wire-for-Earthin

## Installation

### Waveguide

- Insert the O-ring into the groove, and then use M4 screws to connect the antenna connector with waveguide tightly.

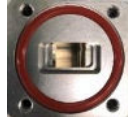

### IF Connector

- Connect the IF Input Connector on BUC with IF Output Connector in modem.

### Power Connector

- This device only supports 85~265 VAC AC power supply. Please connect the power connector correctly according to the following instructions:

- Assemble as shown in 1~6 arrangement (note the direction of each part): 1 rubber core, 2 rubber plugs, 3 rubber sleeves, 4 shells, 5 tail clips, 6 tail clip screws

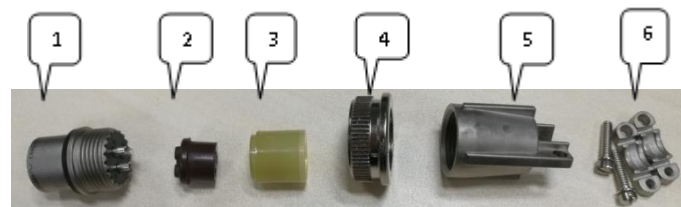

- The wires pass through the 2~5 parts from the center, and then are respectively welded to the rubber core 1 (see the third point for the circuit connection diagram) to ensure that the solder joints are level;

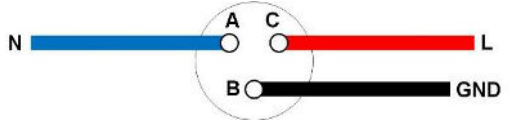
Marking	Cable polarity	Schematic
A	Neutral wire (N)	
B	Ground (GND)	
C	Live wire (L)	

- After the welding is completed, the rubber plug 2 closely adheres to the rubber core 1 along the wire, completely covering the solder joints;



- Then the rubber sleeve 3 is put on the rubber stopper, then the tail clamp 5 is tightened, and finally the tail clamp screw 6 is used to fix it;

## M&C Connector

- This equipment supports three M&C types: RS-485, RS-232, and Ethernet (Http), please select required M&C type to assemble the connector.

Mark	M&C Type	Signal	DB9/RJ45	Pins Diagram
A	RS-485	TX+	3	
B		TX-	4	
D		RX+	1	
C		RX-	2	
L	RS-232	TX	2	
M		RX	3	
H		GND	5	
R	Ethernet (http)	TX+	1	
P		TX-	2	
N		RX+	3	
J		RX-	6	

BUC Signal Direction: TX: BUC to Modem, RX: Modem to BUC

## Installation Direction and Space

- Horizontal installation  
Cooling fan side shall be set to downward direction

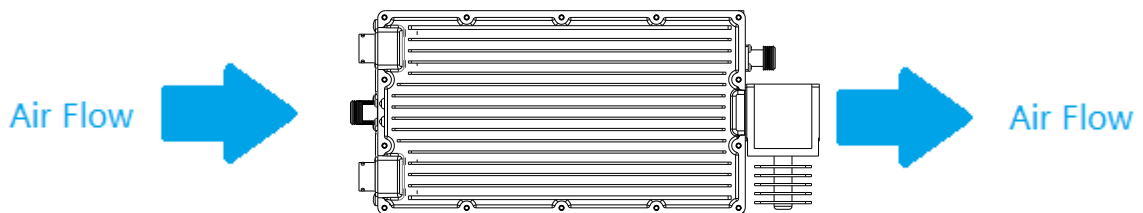

- Vertical installation  
Power connector side shall be set to downward direction
- Space  
Keep more than 40mm of space from inlet/outlet of cooling fan.

## BUC Operation

### One-BUC mode Operation Instructions

- Connection Diagram

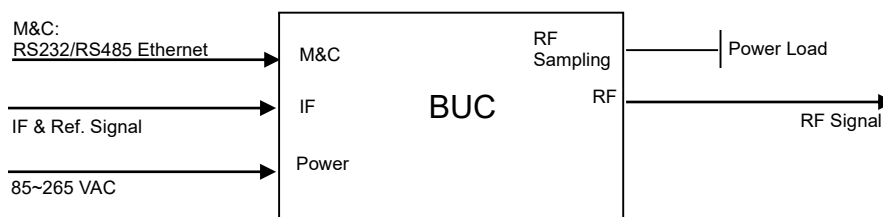

BUC Connection Diagram

## ■ Operation Steps

- (1) Connect BUC with other required equipment as above diagram instruction.
- (2) Ensure the voltage meet the BUC requirements, then power to the BUC.
- (3) Input suit able IF signal:

a. The IF frequency range:

RF Range	IF Range
14 – 14.5 GHz	950-1450 MHz
13.75 – 14.5 GHz	950-1700 MHz

b. The initial signal level shall be about -35 dBm, improve the signal level after BUC performing normally.

- (4) Input the external reference signal(10 MHz,  $0 \pm 5$  dBm), and the BUC will enable to transmit RF signal.
- (5) Check the BUC status and configure the BUC's parameters by GUI or WEB GUI in computer
- (6) Adjust the IF signal level to let the BUC work on the required status.

## ■ GUI Installation

Double click setup.exe to entry installation steps, and install the GUI according to the instruction in popup windows.

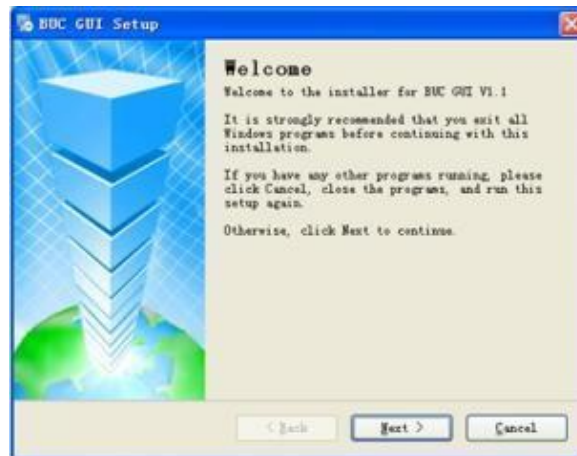

## ■ GUI Operation

(1) Running GUI, users can choose three communication modes (RS-232/RS-485/Ethernet) to connect BUC and select serial password for computer, select the mode "1+0" or "1+1" to configure, and click "Configure";

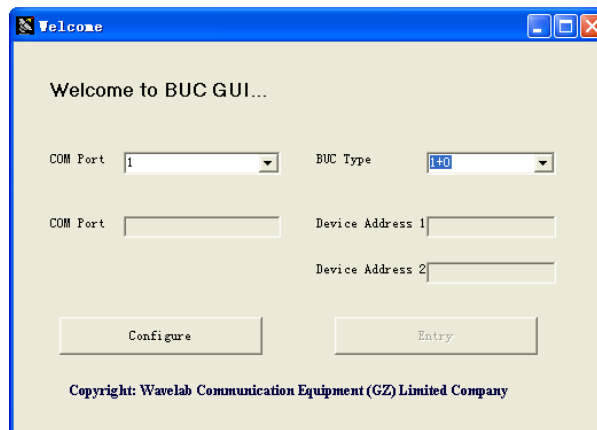

- (2) After inquiring the address number, click the "Entry" button and enter the GUI.

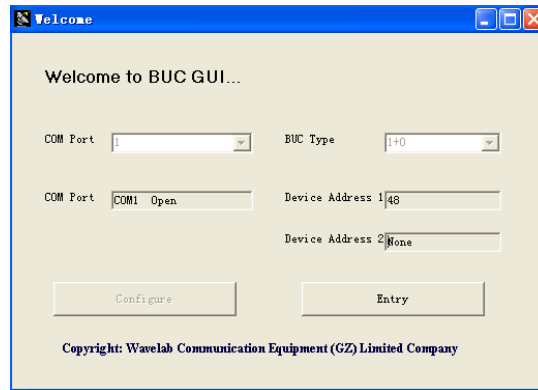

- (3) Enter the GUI interface, including:

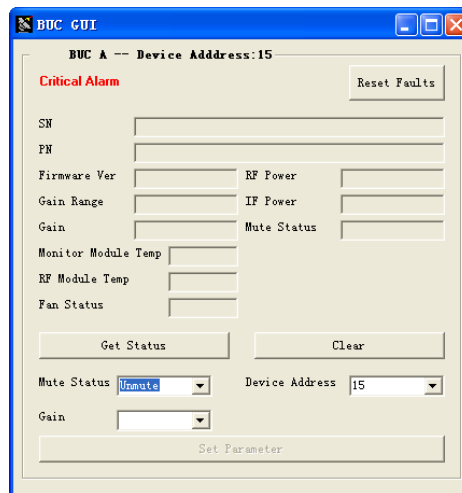

- Get Status: Click the button to query all BUC status information.
- Set Parameter: After inquiring BUC status information, the button is available. Gain, Mute Statures and device number (15-255) can be configured at this time.
- Clear: Click this button to clear all information in the query interface.
- SN: Serial number.
- PN: Product model.
- Firmware Ver: Product firmware version.
- Gain Range: Gain can be set in a range, unit dB.
- Gain: Current gain, unit dB.
- Monitor Module Temp: Monitoring module temperature, unit°C.
- RF Module Temp: Power Amplifier Module Temperature, unit°C.
- Fan Status: Fan speed status.
- RF Power: KU band transmit output power, unit dBm, background refresh every 1 second.
- IF Power: L band intermediate frequency input power, unit dBm.
- Mute Status: Unmute/Mute power amplifier status, background refresh every 1 second.
- Device Address: The device address can be set.
- Gain: The gain can be set in the range of 50-70.

## 1+1 Redundant System Operation Instructions

### ■ System Connection

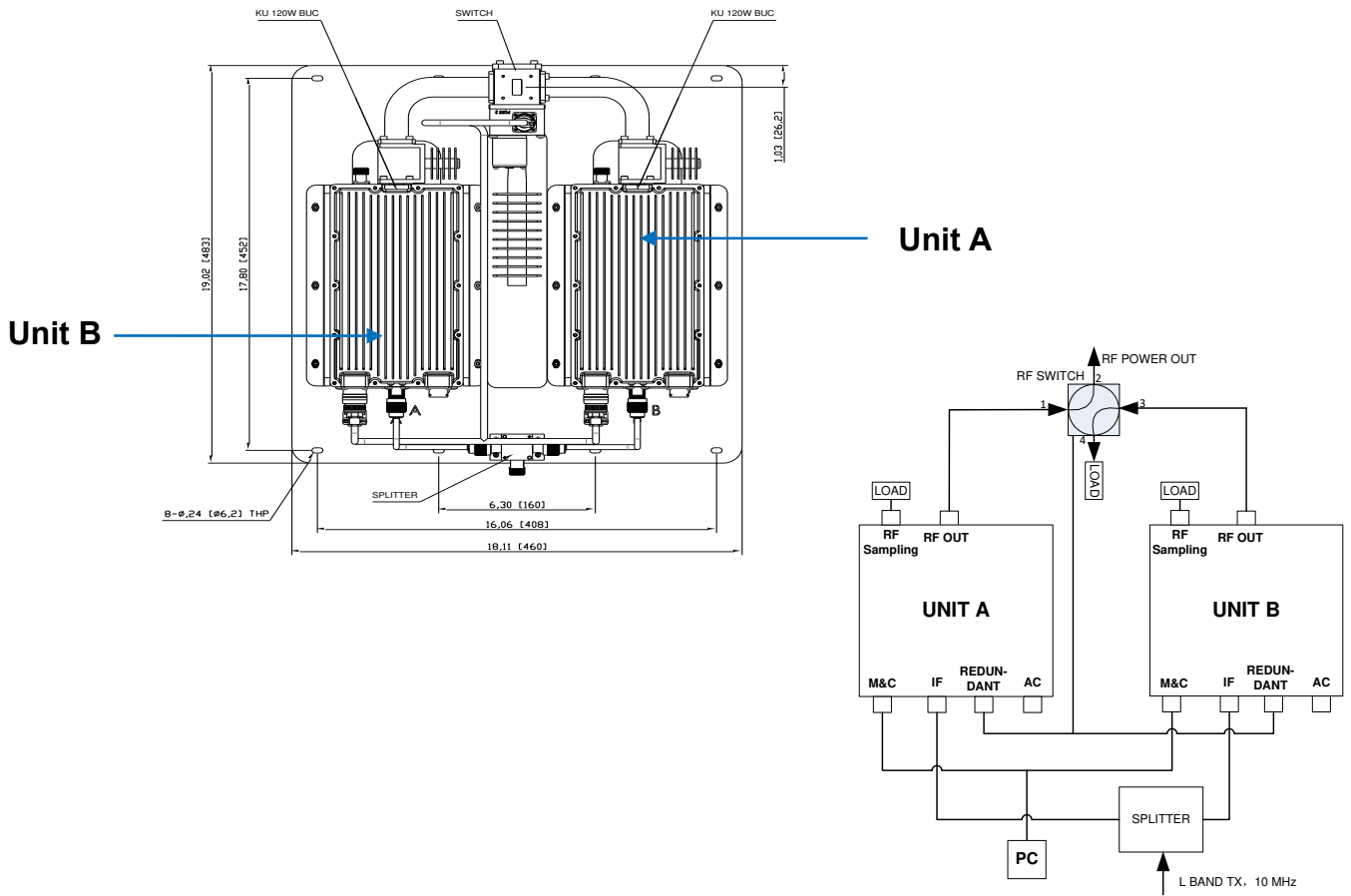

### ■ System Operation Steps

- (1) Connect BUC with other required equipment as above diagram instruction.
- (2) Ensure the voltage meet the BUC requirements, then power to the BUC.
- (3) Input suit able IF signal:

a. The IF frequency range:

RF Range	IF Range
14 – 14.5 GHz	950-1450 MHz
13.75 – 14.5 GHz	950-1700 MHz

b. The initial signal level shall be about -35 dBm, improve the signal level after BUC performing normally.

- (4) Input the external reference signal(10 MHz, $0 \pm 5$  dBm), and the BUC will enable to transmit RF signal.
- (5) Check the BUC status and configure the BUC's parameters by GUI in computer.
- (6) Adjust the IF signal level to let the BUC work on the required status.

## ■ GUI Operation

(1) Run the GUI, select the serial password, select the mode "1 + 1" that needs to be configured, and click "Configure"

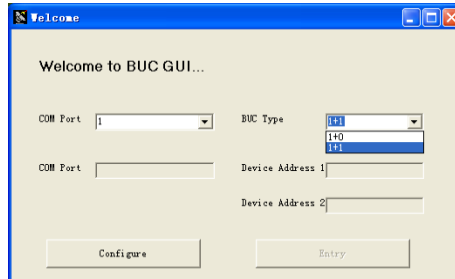

(2) Confirm that the selected serial number is available. Query out 2 device numbers. Entry button is available. Click and enter GUI.

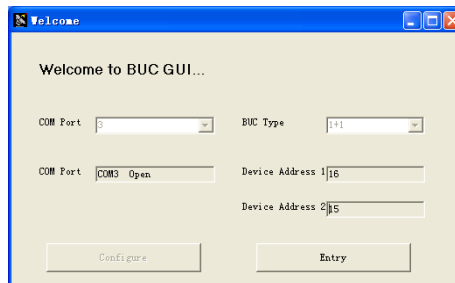

(3) Enter the GUI interface



- Get Status: Click the button to query all BUC status information.
- Set Parameter: After inquiring BUC status information, the button is available, and the working parameters of the product can be set at this time.
- Clear: Click this button to clear all information in the query interface.
- Critical Alarm and 1+1 Alarm: Real-time display of current alarm information.
- Work Mode: Four system working modes: (1) 1 + 0 (One-BUC mode), (2) Auto, Cold (automatic mode cold backup), (3) Manual, A Online (manual mode A online), (4) Manual, B Online (manual mode B online).
- RF Power, Mute Status, Online status, Work Mode, Alarm: Information is queried in real time (background refreshes every 1 second).
- Reset Faults: It is used to clear the power alarm that can not be automatically eliminated.
- Mute Status: Unmute/Mute power amplifier status.

- **Work Mode:** Setting up the working mode under BUC A/B at the same time.
- **Gain:** Set the gain values of BUC A and BUC B in the range of 50-70.
- **1+0:** This mode is One-BUC mode. The default state is Online Unit Open Amplifier (Unmute) and Offline Unit Close Amplifier (Mute).
  - Auto, Cold: This mode is automatic cold backup mode. The default state is Online Unit open power amplifier (Unmute) and Offline Unit off power amplifier (Mute). When online Unit alarm occurs, it will automatically switch to Offline Unit and turn on the power amplifier. When the alarm is lifted, it will not be cut back.
  - Manual, A Online: Manual selection of Unit A online will not automatically switch.
  - Manual, B Online: Manual selection of Unit B online will not automatically switch.
- In Manual mode, the system will not switch automatically. It is used to select the required worker. If you want to switch to the backup machine when there is Alarm, please switch to auto.
- Switching between Manual, A Online and Manual, B Online requires both A and B to be in Mute state.
- In Auto mode, the online unit and Offline Unit are determined according to the location of RF Switch.

## Connecting computers with browsers

Users can choose Ethernet (Http) to connect BUC and computer through browser (recommend using Google or Firefox, etc.). The specific operation is as follows:

**Ethernet (Http):** Setting computer IP and BUC IP in the same network segment, the default IP of the two BUCs are 192.168.1.1, they need to be set differently when working. Please change the IP address according to the actual situation.

- Open a browser and enter 192.168.1.1 (default address) in the address bar.

➤ **BUC info:**

S/N: serial number.

P/N: product model.

Software(Firmware/Web Server): Product firmware version.

BUC Info	
BUC	
P/N	WLB-KUE1H-00A0W-A0
S/N	C180300898
Software	
Firmware	1.4
Web Server	1.3

➤ **BUC status:**

IF Power: Input IF signal power.

RF Power: Output RF signal power.

BUC Gain: Current gain.

Fan Speed: Fan speed, 100% represents full speed.

Mute Status: Mute is closed and Unmute is open.

Temperature: Current temperature.

BUC Status	
General	
IF Power	-32.5 dBm
RF Power	-50 dBm
BUC Gain	64 dB
Fan Speed	100%
Mute Status	Mute
Temperature	19 °C

➤ **BUC Alarm:**

PLL: PLL Alarm.

Fan: Fan Alarm.

HPA: HPA Alarm.

Temperature: Temperature Alarm.

BUC Alarm	
General	
PLL	Lost
Fan	Normal
HPA	Normal
Temperature	Normal

➤ **BUC Settings:**

BUC Gain: Gain settings, ranging from 50 to 70 dB.

Tx Mute: Mute is closed and Unmute is open.

BUC Settings		
BUC Gain		
64 dB	<input type="text" value="64"/>	<input type="button" value="Set"/>
Tx Mute		
Mute	<input type="text" value="Mute"/>	<input type="button" value="Set"/>

➤ **Redundancy:**

(1) 1:1 Settings:

Redundancy Mode:

Redundancy Mode	Mode instructions	Handover instructions
OFF	This mode is One-BUC mode. The default state is Online Unit Open Amplifier (Unmute) and Offline Unit Close Amplifier (Mute).	<ol style="list-style-type: none"> <li>1. Can switch directly to Auto mode, Online unchanged, into automatic cold backup mode.</li> <li>2. When switching to Manual, A or Manual, B mode, Online unit will switch to A or B correspondingly.</li> </ol>
Auto	This mode is automatic cold backup mode. The default state is Online Unit open power amplifier (Unmute) and Offline Unit off power amplifier (Mute). When online Unit alarm occurs, it will automatically switch to Offline Unit and turn on the power amplifier. When the alarm is lifted, it will not be cut back.	<ol style="list-style-type: none"> <li>1. It can be switched directly to OFF mode, Online is unchanged, and it can be operated in One-BUC mode.</li> <li>2. When switching to Manual, A or Manual, B mode, Online unit will switch to A or B correspondingly.</li> </ol>
Manual, A	Manual selection of Unit A online will not automatically switch.	<ol style="list-style-type: none"> <li>1. It can be switched directly to OFF mode. Online is Unit A, and it can be operated in One-BUC mode.</li> <li>2. It can switch to Auto mode directly. Online is Unit A, and it can enter automatic cold backup mode.</li> <li>3. Can switch directly to Manual, B mode, Online to Unit B;</li> </ol>
Manual, B	Manual selection of Unit B online will not automatically switch.	<ol style="list-style-type: none"> <li>1. It can be switched directly to OFF mode. Online is Unit B, and it can be operated in One-BUC mode.</li> <li>2. It can switch to Auto mode directly. Online is Unit B, and it can enter automatic cold backup mode.</li> <li>3. Can switch directly to Manual, A mode, Online to Unit A.</li> </ol>

Monitor Interface Type: RS485 and Ethernet can be selected.

RS485 Address: If RS485 is selected as the monitoring interface type, the address of BUC connection is set here.

(2) 1:1 Status: Include Online Status and BUC Position.

(3) 1:1 Alarm:

Alarm	Alarm Note
Partner Status	If there is a problem with the connection state between redundant systems, an alarm will be given
BUC Mode	The mode choice of the two BUCs should be the same, otherwise they will be warned.
Gain Status	The gain settings of the two BUCs need to be consistent, otherwise they will be alarmed.
RS485 Address	When connecting through RS485, the addresses of the two BUCs should be set differently, otherwise they will alarm.

If the above alarms occur, the 1:1 system will not automatically switch.

Redundancy	
1:1 Settings	
Redundancy Mode	Manual A <input type="button" value="Set"/>
Monitor Interface Type	Ethernet <input type="button" value="Set"/>
RS485 Address	16 <input type="button" value="Set"/>
1:1 Status	
Online Status	Online
BUC Position	A
1:1 Alarm	
Partner Status	Normal
BUC Mode	Normal
Gain Status	Normal
RS485 Address	Normal

➤ **IP Settings:**

Current IP: Query the current IP address, subnet mask and gateway settings.

Static IP: Please set it according to the actual network configuration and click Set to complete the settings.

IP Settings	
Current IP	
IP Address	192.168.1.1
Subnet Mask	255.255.255.0
Gateway	192.168.1.254
Static IP	
IP Address	<input type="text" value="192.168.1.1"/>
Subnet Mask	<input type="text" value="255.255.255.0"/>
Gateway	<input type="text" value="192.168.1.254"/>
<input type="button" value="Set"/>	

## (2) Update Firmware by webservice

- Users can select Ethernet (http), via a browser (it is recommended to use Google or Firefox) to connect the BUC and computer, concrete operation is as follows:
  - **Ethernet (http):** Set the computer IP and the BUC IP in the same network segment, BUC factory IP address is 192.168.1.1, then opens a browser and type in the address bar and opens the 192.168.1.1.
  - **When you are ready to update firmware by webservice, please checked whether have set the computer IP and the BUC IP in the same network segment.**
  - **In the address bar, enter the BUC's access IP address. The BUC's default IP address is 192.168.1.1. A welcome page similar to the one below should display, and then please click choose file**

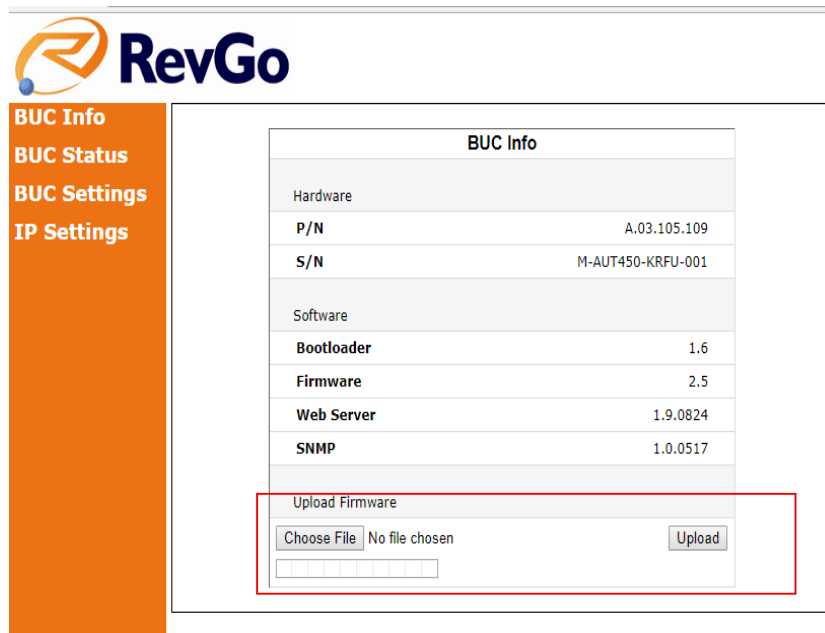

- **Click choose File**

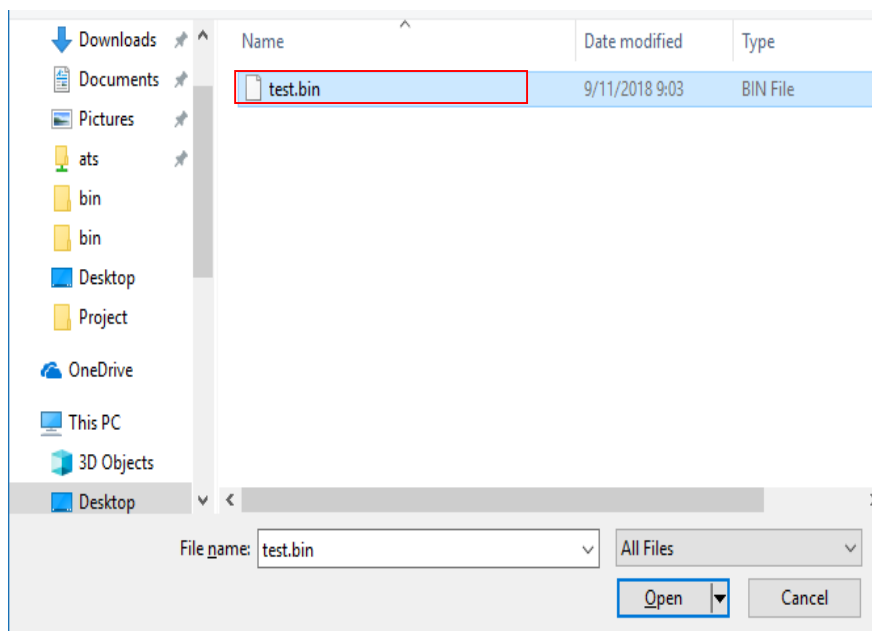

- Choice the bin file which you need to upgrade, and click “open”

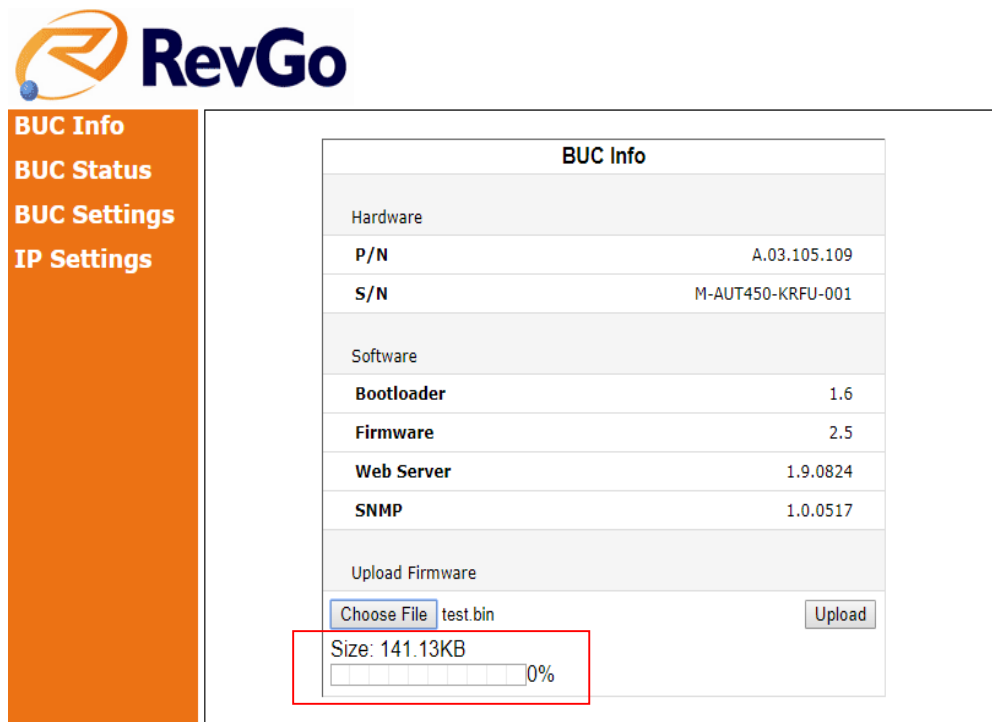

The screenshot shows the RevGo interface with a sidebar on the left containing navigation links: BUC Info, BUC Status, BUC Settings, and IP Settings. The main content area is titled 'BUC Info' and contains a table with hardware and software details. Below the table is an 'Upload Firmware' section with a 'Choose File' button, the filename 'test.bin', and an 'Upload' button. A progress bar below the filename shows 0% completion. A red box highlights the 'Size: 141.13KB' and the progress bar.

BUC Info	
Hardware	
P/N	A.03.105.109
S/N	M-AUT450-KRFU-001
Software	
Bootloader	1.6
Firmware	2.5
Web Server	1.9.0824
SNMP	1.0.0517
Upload Firmware	
Choose File	test.bin
Size: 141.13KB	
0%	

- **Note:** please wait until the file has been uploaded (as shown in the red box, display the upgrade file name and file size), click “Upload” and start the upgrade

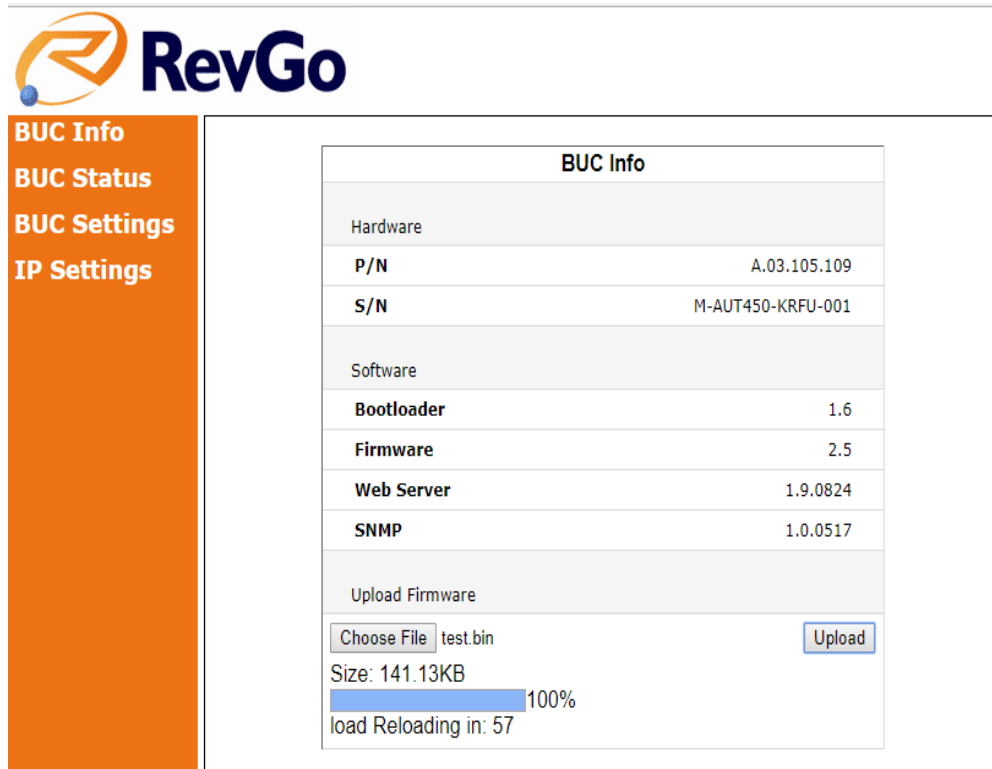

The screenshot shows the RevGo interface with the same sidebar and 'BUC Info' table as the previous image. In the 'Upload Firmware' section, the 'Choose File' button is now disabled, and the 'Upload' button is active. The progress bar is now filled to 100%. Below the progress bar, the text 'load Reloading in: 57' is displayed.

BUC Info	
Hardware	
P/N	A.03.105.109
S/N	M-AUT450-KRFU-001
Software	
Bootloader	1.6
Firmware	2.5
Web Server	1.9.0824
SNMP	1.0.0517
Upload Firmware	
Choose File	test.bin
Size: 141.13KB	
100%	
load Reloading in: 57	

- When the progress bar displays 100% and load Reloading in: XX, it indicates that the upgrade is successful. After that, the page can be refreshed manually, or the page will be refreshed automatically after 60 seconds.