



215560-001,004&005MD

Power Supply 90/264Vac +Bias tee

Operation and Maintenance Manual



This page has been intentionally left blank.

Mitec Telecom Inc.

Designers and manufacturers of telecom and wireless products

3299 Jean-Baptiste-Deschamps
Lachine, QC, H8T 3E4
Canada



OPERATION AND MAINTENANCE MANUAL

Preliminary

Released

REVISION RECORD

Revision	ECN #	Description	Date	Approved
0		Engineering Release.	Dec 17, 08	
1		Added new configurations 004 & 005	Mar 17, 10	

CM Approval

TITLE:

**215560-001,004,005MD
Power Supply 90/264Vac +Bias Tee**

This document contains information proprietary to mitec telecom inc., or its affiliates, or to a third party to which mitec telecom inc. may have a legal obligation to protect such information from unauthorized disclosure, use, or duplication. Any disclosure, use, or duplication of this document or of any of the information contained herein is expressly prohibited except as mitec telecom inc. may otherwise agree in writing.

Designer: Normand Roy Date: 17 Dec, 08

REV 1

Technical Writer: Ravinder Date: 17 Dec, 08

**DOCUMENT NO.
215560-001,004,005MA**

PAGE 1 OF 26

This page has been intentionally left blank.

Table of Contents

1 INTRODUCTION	3
1.1 Receiving and Inspection	4
1.1.1 Equipment Damage or Loss	4
1.1.2 Return of Equipment	4
1.2 Preparing for Installation	5
1.2.1 Safety Precautions	5
2 INSTALLATION & OVERVIEW.....	6
2.1 General Description	6
2.2 Specifications	6
2.2.1 General Considerations	7
2.3 Basic Mechanical Characteristics	7
2.3.1 External View of the Module	7
2.3.2 Connections and Mounting Hardware.....	7
2.4 Assembly and Installation.....	8
2.4.1 Lifting the Module into Position and Temporary Attachment	8
2.4.2 Securing the Module.....	8
2.5 Functional Overview	9
2.5.1 General	9
3 OPERATION	11
3.1 Procedure	11
3.2 Connector Interface	11
4 MAINTENANCE	13
4.1 Preventive Maintenance.....	13
4.1.1 Procedure.....	13
4.1.2 PSU Module System Preventive Maintenance.....	13
4.1.3 Performance Check.....	13

4.1.4	Troubleshooting.....	14
4.1.5	Out-of Warranty Repair.....	14

APPENDIX A 1

Drawings & Schematic Diagrams	1
--	----------

APPENDIX B 1

Spare Parts	1
--------------------------	----------

List of Tables

Table 1 –Specifications.....	6
Table 2 - Recommended Corrective Actions.....	14

List of Figures

Figure 1 - Power Supply	3
Figure 2 - Module Block Diagram.....	9
Figure 3 - System Block Diagram	9
Figure 4 - 215560-001MD - Power Supply 90/264Vac +Bias Tee - Outline Drawing.....	1

Preface

Scope

This document covers the installation, operation, and maintenance of the 215560-001,004,005MD Power Supply 90/264Vac +Bias Tee. It contains information intended for engineers, technicians and operators working with the transmitter module.

To make inquiries, or to report errors of fact or omission in this document, please contact the technical writing department at **Mitec Telecom Inc.** at (514) 694-9000.

IMPORTANT

Important information concerning the operation and care of this product, as well as safety of authorized operators is highlighted throughout this document by one of the following labels:

NOTE

Indicates a reminder, a special consideration, or additional information that is important to know.

CAUTION!

Identifies situations that have the potential to cause equipment damage.

WARNING!!

Identifies hazardous situations that have the potential to cause equipment damage as well as serious personal injury.

This page has been intentionally left blank.

1 Introduction

The Power Supply 90/264Vac +Bias Tee module is a highly reliable, high quality, cost efficient 48V Power supply system designed for use in VSAT applications. This line of superior products, engineered using state of the art technology, is characterized by unparalleled durability and dependability. Refer to Table 1 for specification.

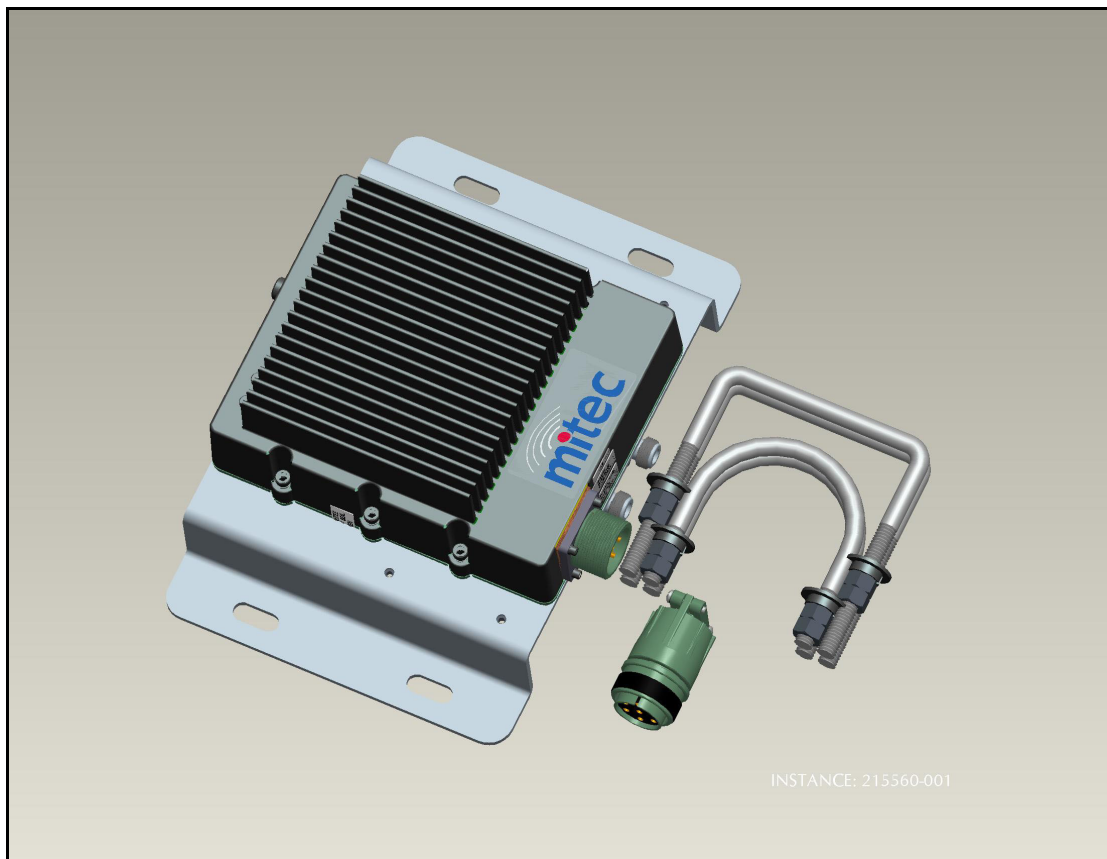

Figure 1 - Power Supply

1.1 Receiving and Inspection

The Power Supply module is designed to function outdoors and will arrive in standard shipping containers. Immediately upon receipt of the Power Supply module, check the Bill of Lading against the actual equipment you have received. Inspect the shipping containers exteriors for visible damage incurred during shipping.

CAUTION!

Handle the transmitter module with extreme care. Excessive shock may damage transmitter module's delicate internal components.

NOTE

Before unpacking the shipping containers, move them near to the site where the system will be mounted. Ensure that the containers are oriented correctly in accordance with the "This Side UP" labels. Carefully remove the transmitter module and packing material from the shipping containers.

Using the supplied packing list, verify that all items have been received and undamaged during shipment. Verify that all items are complete. If there are any omissions or evidence of improper packaging, please notify **mitec telecom inc.** immediately.

1.1.1 Equipment Damage or Loss

Mitec Telecom Inc. is not responsible for damage or loss of equipment during transit. For further information, contact the responsible transport carrier.

When declaring equipment as damaged during transit, preserve the original shipping cartons to facilitate inspection reporting.

1.1.2 Return of Equipment

When returning equipment to **mitec** for repair or replacement:

1. Identify, in writing, the condition of the equipment,
2. Refer to the sales order, Purchase Order and the date the equipment was received.

Notify **Mitec** Sales Administration Department of the equipment condition and obtain a Return Material Authorization (RMA) number and shipping instructions. **Mitec** will pay for the cost of shipping the product to the customer after the repairs are completed.

NOTE

Do not return any equipment without an RMA number. This is important for prompt, efficient handling of the returned equipment and of the associated complaint.

1.2 **Preparing for Installation**

Before attempting to install or use the Power Supply module, we recommend that you first familiarize yourself with the product by reading through this manual. Understanding the operation of the system will reduce the possibility of incorrect installation, thereby causing damage or injury to yourself or others.

*The transmitter module **must** be installed in accordance with the conditions and recommendations contained in the following sections.*

When you are ready to begin your installation, use the information in Chapter 2 (Installation) as a guide for making all the required electrical connections.

1.2.1 **Safety Precautions**

Carelessness or mishandling of the transmitter module may damage the unit causing serious injury to yourself or others.

This page has been intentionally left blank.

2 Installation & Overview

2.1 General Description

This section describes the installation and theory of operation of the 215560-001,004,005MD.

The module is a stand-alone Power Supply + Bias Tee System. Powered from an AC power source.

The module consists of a +48Vdc power supply and a bias tee. The power supply provides the +DC voltages to the RF amplifier via the IF connector on the bias tee. The module is capable of providing an output of +48Vdc at 8 amp. The module is for outdoor use and is secured onto a mounting boom mount mounting bracket. The four inches U bolts are supplied.

2.2 Specifications

Table 1 summarizes the specifications of the Power Supply 90/264Vac +Bias Tee. For mechanical specifications, refer to the outline drawing in Appendix A. Table 1 below lists the specifications.

Table 1 –Specifications

Performance	
IF Input Port DC	DC Blocked
IF Output Port DC	+32 to +50VDC @ 10 Amp max
IF Port Frequency Range	10MHz, 950 to 1825 MHz
Insertion Loss IF input to IF output	-1 dB nom.
Input Return Loss both ports	-12 dB max
AC Input Power Requirement	90 to 264 Vac, 50 to 60Hz, 500W typ.
Mechanical Specifications	
Input Interface	N-type, female (50 ohm)
Output Interface	N-type, female (50 ohm)
Package	Outdoor, weather resistant
Size (overall dimensions)	8.0500" x 6.2251" x 3.3425" (204.47mm x 158.117mm x 84.899mm)
Weight	10 lbs (4.535 kg)

Environmental	Operational	Storage
Temperature Range	-40° to +55°C	-40°C to +75°C
Humidity	0 to 100%	
Altitude	15,000 ft AMSL	

NOTE

Technical specifications are subject to change without notice.

2.2.1 General Considerations

The module shall meet all specifications over full bandwidth and under all environmental conditions.

2.3 Basic Mechanical Characteristics

2.3.1 External View of the Module

The physical external dimensions of the transmitter module are shown in the outline drawing in Appendix A and Table 1. All inputs and outputs are shown in the outline drawing

2.3.2 Connections and Mounting Hardware

The connections require a coaxial cable with an N-type male connector for the IF Input and output. A DC input connection using a MS3106E20-15P type connector.

The PSU is mounted using the 2 U bolt supplied with the unit.

2.4 **Assembly and Installation**

Use the information in this section as a guide to assemble and install the transmitter module.

CAUTION!

Only authorized technical personnel should perform the Installation and proper electrical hookups of the transmitter module.

2.4.1 Lifting the Module into Position and Temporary Attachment

The module weighs approximately 10lbs, which may be handled by a single person. Remove all plastic caps from the connectors. The module is now ready for permanent attachment.

2.4.2 Securing the Module

Secure the Power Supply module on to the boom or the mass using the hardware described in section 2.3.2. Attach the proper cable for IF input and IF output to the corresponding connector of the modem and BUC. Refer to the Figure 2 - system bloc diagram.

NOTE

The connectors are labeled clearly and has different pin layout. Refer to the outline drawing in Appendix A. It is impossible to incorrectly install the mating connectors.

The Power Supply module requires a steady flow of air. To provide a sufficient airflow, the Power Supply module shall be properly oriented, with the deepest heat sink fins facing up, and mounted with a minimum clearance of 3.0 inches on all sides of the Power Supply module. Adequate cooling for the Power Supply module will provide years of top performance.

2.5 Functional Overview

2.5.1 General

This section describes the module functions in detail. The functional overview explains the power distribution. Figure 2 block diagram illustrates the module.

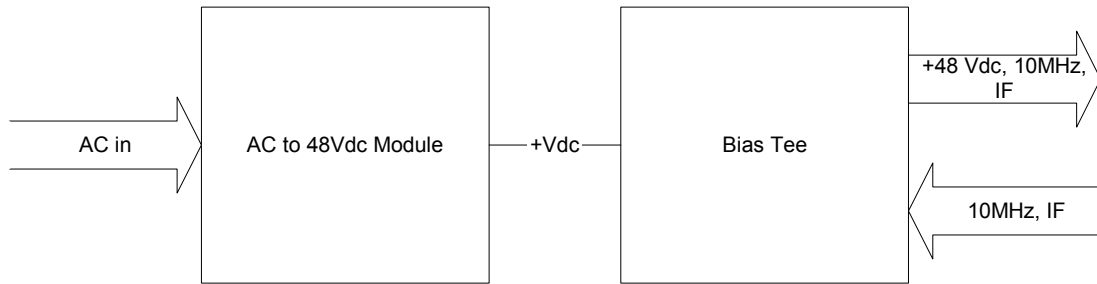

Figure 2 - Module Block Diagram

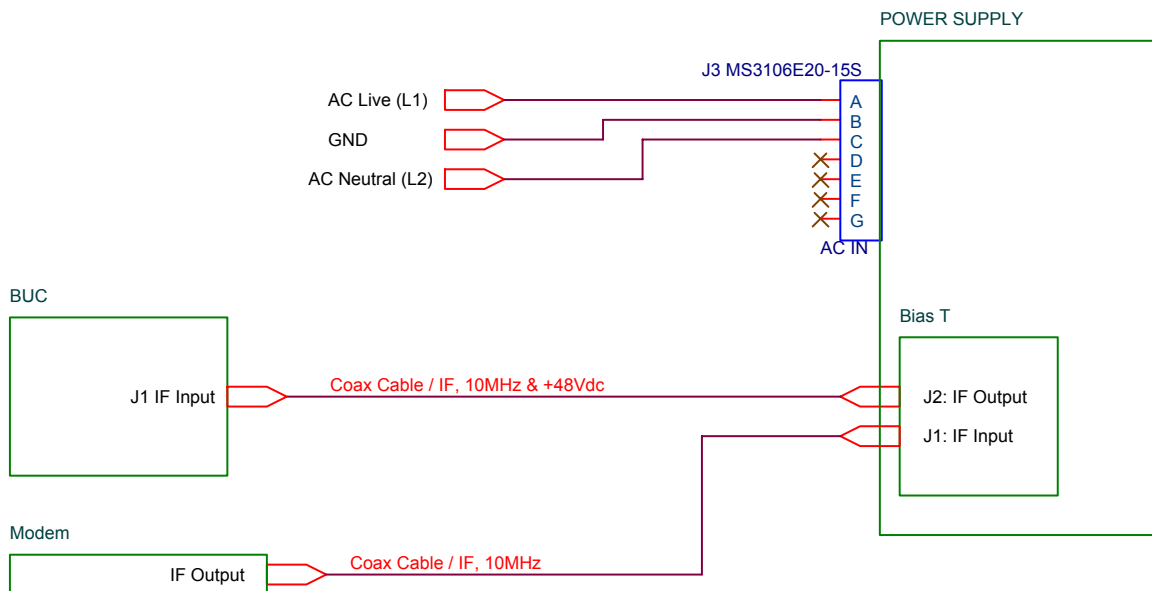

Figure 3 - System Block Diagram

3 *Operation*

This chapter describes the verification of the operation of the Power Supply module. It shall be performed by authorized personnel prior to maintenance and/or repair.

3.1 *Procedure*

Verify that the installation procedure described in Chapter 2 was completed. A complete physical check of the customer’s system is suggested.

Turn ON the power and allow a warm up period before operating the transmitter module. This will assure stable gain and power.

3.2 *Connector Interface*

Connector Name	Type		Pin #	Signal Name	Description	Parameter
J1 “IF IN”	215560-001	N-Type Female	N/A	IF Input	IF Input	10MHz, 950 to 1825 MHz
	215560-004	F-Type Female				
	215560-005	F-Type Female				
J2 “IF OUT”	215560-001	N-Type Female		IF Output	IF Output	10MHz, 950 to 1825 MHz With +48VDC
	215560-004	F-Type Female				
	215560-005	N-Type Female				
J3 “AC INPUT”	MS3102R20-15P		A	L1	Line	90/264VAC 50 – 60 Hz 500W nom
			B	GND	Ground	
			C	L2	Neutral	

This page has been intentionally left blank.

4 Maintenance

This chapter contains information on how to maintain and troubleshoot the Power Supply module. The Power Supply module is extremely reliable, requiring very little preventive maintenance, or repair. Should there be a malfunction, this chapter also contains technical information to help diagnose basic failures.

4.1 Preventive Maintenance

4.1.1 Procedure

WARNING!

Shut down the module before disassembly and remove all cables and connections. Failure to observe this precaution may result in personal injury or death. This includes the removal of any RF power originating from other system components.

4.1.2 PSU Module System Preventive Maintenance

Preventive maintenance is limited to checking the performance of the Power Supply module. No electrical or mechanical adjustments are required for normal operation. Periodic cleaning of the heat sink fins will ensure adequate ambient cooling.

4.1.3 Performance Check

Verify the system is properly set up as per Chapters 2 and 3.

It is recommended to measure the following parameters for ensuring that the Power Supply module is in good working condition:

- Insertion Loss IF input
- Input and output Return Loss
- Presence of +48Vdc on the IF output center pin.

4.1.4 Troubleshooting

WARNING!!

Cable connection and disconnection shall be done carefully to avoid physical damage to the cables and connectors, which may cause intermittent problems in the future.

Use Table 2 to quickly isolate a fault within the Power Supply module. If the Power Supply module is defective, notify **mitec** and follow the process detailed in section 1.1.2.

Symptom	Action
Fails performance test	Check power source, IF source, 10 MHz source, cabling and connectors. Check for debris in heat sink fins. Clean thoroughly. return to mitec.

Table 2 - Recommended Corrective Actions

4.1.5 Out-of Warranty Repair

A non-warranty and out-of-warranty repair service is available from **mitec** for a nominal charge. The customer is responsible for paying the cost of shipping the module both to and from **mitec** for these repairs.

Appendix A

Drawings & Schematic Diagrams

215560-001,004,005MD - Power Supply 90/264Vac +Bias Tee - Outline Drawings

This page has been intentionally left blank.

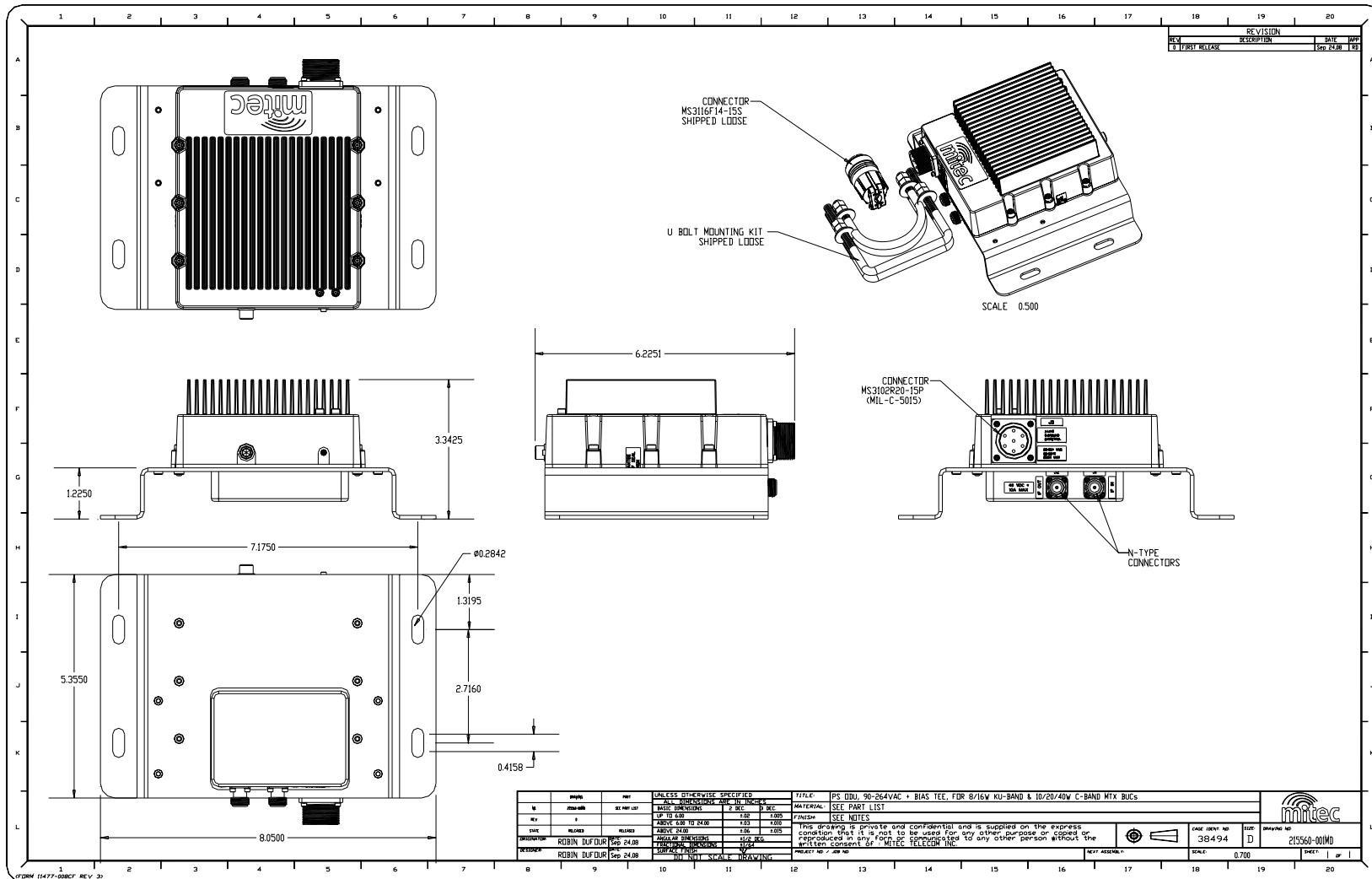

Figure 4 - 215560-001MD - Power Supply 90/264Vac +Bias Tee - Outline Drawing

This page has been intentionally left blank.

Appendix B

Spare Parts

Appendix B contains a table of recommended spare parts for on-hand replacement. The following sheet can be copied and used as a fax form to order the required spare parts. Please make sure to include all identifying information to facilitate the processing of your order. The order may also be sent via email or regular mail delivery, at the following address.

mitec telecom inc.
3299 Jean-Baptiste-Deschamps
Lachine, QC, H8T 3E4
Canada

Fax: (514) 694-3814
Email: sales@mitectelecom.com

For additional information, please contact our customer service department at:
(514) 694-9000 or 1-800-724-3911

This page has been intentionally left blank.

Mitec Telecom Inc.

*Designers and manufacturers of telecom & wireless products
ISO 9001 Certified*



Spare Parts Order Form

**215560-001,004,005MD
Power Supply 90/264Vac
+Bias Tee**

From:

Place By:

Signature:

Telephone:

Fax

Email:

Part Description

Part Number

Quantity

**Unit
Price***

**Line
Total***

* To be completed by **mitec** Sales Department

Fax to: Customer Service (514) 694-3814