

# COMTECH EFData CORPORATION CRS-200 REDUNDANCY SWITCH OPERATIONS MANUAL

## CONTENTS

<b>1</b>	<b>SAFETY NOTICES</b>	<b>1</b>
	1.1 ELECTRICAL SAFETY	1
	1.2 TELECOMMUNICATIONS TERMINAL EQUIPMENT DIRECTIVE	2
	1.3 EMC (ELECTROMAGNETIC COMPATIBILITY)	2
<b>2</b>	<b>DESIGN PHILOSOPHY</b>	<b>4</b>
<b>3</b>	<b>CRS-200 OVERVIEW</b>	<b>5</b>
<b>4</b>	<b>PHYSICAL DESCRIPTION</b>	<b>7</b>
	4.1 FRONT PANEL	7
	4.2 REAR PANEL	8
<b>5</b>	<b>FUNCTIONAL DESCRIPTION</b>	<b>12</b>
<b>6</b>	<b>CONNECTOR PINOUTS</b>	<b>16</b>
	6.1 DATA CONNECTOR	16
	6.2 SYSTEM ALARMS CONNECTOR	17
	6.3 IF SWITCH CONTROL CONNECTOR	18
	6.4 REMOTE CONTROL CONNECTOR	18
<b>7</b>	<b>INSTALLATION</b>	<b>19</b>
	7.1 UNPACKING	19
	7.2 MOUNTING	19
	7.3 CONFIGURATION	19

<b>8</b>	<b>SETUP GUIDE</b>	20
8.1	25-PIN DATA CABLES	20
8.2	INITIAL CRS-200 SETUP	22
8.3	IF CABLES AND TRANSPONDER SWITCH	23
8.4	ADDITIONAL SWITCH CONFIGURATION	26
<b>9</b>	<b>FRONT PANEL OPERATION</b>	27
9.1	DESCRIPTION	27
9.2	MENU TREE	28
<b>10</b>	<b>FLASH UPGRADING</b>	40
<b>11</b>	<b>SUMMARY OF SPECIFICATIONS</b>	41
<b>12</b>	<b>REMOTE CONTROL</b>	43
12.1	INTRODUCTION	43
12.2	RS485	43
12.3	RS232	44
12.4	BASIC PROTOCOL	44
<b>13</b>	<b>CABLE DRAWINGS</b>	54

## IMPORTANT INFORMATION - PLEASE READ BEFORE INSTALLATION AND USE

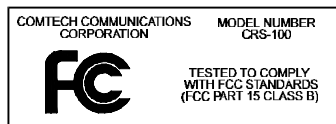
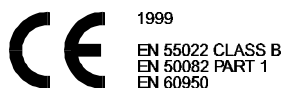

### 1 SAFETY NOTICES

#### 1.1 ELECTRICAL SAFETY

The CRS-200 Redundancy Switch has been shown to comply with the following safety standard:

EN 60950: Safety of Information Technology Equipment, including electrical business machines

The equipment is rated for operation over the range 100 - 240 volts AC. It has a maximum power consumption of 25 watts, and draws a maximum of 250 mA. The user should observe the following instructions:

##### 1.1.1 FUSES

The CRS-200 is fitted with two fuses for each of its two power supply units - one each for line and neutral connections. These are contained within the body of the IEC power inlet connector, behind a small plastic flap.

For 230 volt AC operation, use T0.5A, 20mm fuses.

For 115 volt AC operation, use T1A fuses, 20mm fuses.

**FOR CONTINUED OPERATOR SAFETY, ALWAYS REPLACE THE FUSES WITH THE CORRECT TYPE AND RATING.**

##### 1.1.2 ENVIRONMENTAL

The CRS-200 must not be operated in an environment where the unit is exposed to extremes of temperature outside the ambient range 0 to 50°C, precipitation, condensation, or humid atmospheres above 95% RH, altitudes (un-pressurized) greater than 2000 meters, excessive dust or vibration, flammable gases, corrosive or explosive atmospheres.

Operation in vehicles or other transportable installations that are equipped to provide a stable environment is permitted. If such vehicles do not provide a stable environment, safety of the equipment to EN60950 may not be guaranteed.

### **1.1.3 INSTALLATION**

The installation and connection to the line supply must be made in compliance to local or national wiring codes and regulations.

The CRS-200 is designed for connection to a power system that has separate ground, line and neutral conductors. The equipment is not designed for connection to power system that has no direct connection to ground.

The CRS-200 is shipped with line inlet cables suitable for use in the country of operation. If it is necessary to replace this cable, ensure the replacement has an equivalent specification. Examples of acceptable ratings for the cable include HAR, BASEC and HOXXX-X. Examples of acceptable connector ratings include VDE, NF-USE, UL, CSA, OVE, CEBEC, NEMKO, DEMKO, BS1636A, BSI, SETI, IMQ, KEMA-KEUR and SEV.

## **1.2 TELECOMMUNICATIONS TERMINAL EQUIPMENT DIRECTIVE**

In accordance with the Telecommunications Terminal Equipment Directive 91/263/EEC, this equipment should not be directly connected to the Public Telecommunications Network.

## **1.3 EMC (ELECTROMAGNETIC COMPATIBILITY)**

The CRS-200 Redundancy Switch has been demonstrated, by independent testing, to comply with the following standards:

Emissions: EN 55022 Class B - Limits and methods of measurement of radio interference characteristics of Information Technology Equipment.

FCC Part 15 Class B

Immunity: EN 50082 Part 1 - Generic immunity standard, Part 1: Domestic, commercial and light industrial environment.

In order that the Redundancy Switch continues to comply with these standards, observe the following instructions:

All 'D' type connectors attached to the plug-in interface cards must have back-shells that provide continuous metallic shielding. Cable with a continuous outer shield (either foil or braid, or both) must be used, ***and the shield must be bonded to the back-shell.***

All plug-in interface cards must be secured tightly to the back panel by the built-in captive screws. Blank panels must be used on all un-used Traffic Modem Interface slots.

The equipment must be operated with its cover on at all times. If it becomes necessary to remove the cover, the user should ensure that the cover is correctly re-fitted before normal operation commences.

## 2 DESIGN PHILOSOPHY

Why use a Redundancy Switch?

There is only one answer to this question – to automatically protect satellite traffic circuits against failures in modem equipment, and to hence improve the availability of those circuits.

In order for the Redundancy Switch to carry out its mission, it must be inherently more reliable than the equipment it is protecting. If it is not, then it is a waste of time and money installing it in the first place. There are therefore several key design considerations:

- The design should be electrically and mechanically as simple as possible. The minimum number of electrical components should be used.
- Major elements should be modular, and if a failure in a module should occur, it should be capable of being replaced without any disruption of normal traffic circuits.
- Single point failures should be avoided. This is particularly true of the Power Supply.
- Cabling should be kept to a minimum. Cables are a traditional source of problems.
- The user interface should be as simple as possible – the software needs to be intuitive, and easy to understand.
- Un-necessary switching should be avoided. It wastes time and accomplishes nothing.

COMTECH'S PHILOSOPHY:  
SIMPLE = RELIABLE

The CRS-200 embodies all of these design considerations – the emphasis is on simplicity, without sacrificing functionality.

### 3 CRS-200 OVERVIEW

#### **WARNING**

Please note that the CRS-200 has been designed specifically as an accessory product for the Comtech CDM-500, CDM-550 and CDM-550T Modems,  
***and should not be used with any other manufacturer's equipment.***

The CRS-200 1:10 Redundancy Switch, for use with the CDM-500, CDM-550 and CDM-550T Modems, provides fully automatic protection of traffic circuits in the case of equipment failure, and is intended for hub applications.

If all Modems within a group are connected to the same up/downconverter, no external IF switching is required. However, where operation with more than one up/downconverter is required, the user may add the CRS-280 IF Switch, which permits connection to as many converters as there are Traffic Modems.

The CRS-200 will support all of the interface types available on the modem, which includes RS422/EIA530 DCE, V.35 DCE, X.21 DCE and DTE and RS232, sync and async. Note that, unlike many other products of this type, ***electrical interface types may be mixed within the same redundancy group.***

The CRS-200 incorporates the following key reliability features:

- \* The CRS-200 has twin, independent AC power supplies
- \* Normal traffic paths are maintained, error free, when AC power is removed
- \* A Traffic Modem Interface can be completely removed from the CRS-200, with its cables still attached, and traffic will not be interrupted
- \* Traffic Modem Interfaces (TMI) and the Redundant Modem Interface (RMI) can be replaced without disturbing other traffic circuits

When operating with a single up/downconverter, the system comprises a maximum of 10 Traffic Modems, a Redundant Modem, and the CRS-200 Protection Switch. All IF inputs and outputs are passively split and combined. The redundant modem is in remote control mode,

and the traffic modems may be in local or remote mode. All of the modems are connected to the CRS-200 Protection Switch via a single 25-pin cable (which connects, data, alarms, and an RS232 link). The RS232 link permits the CRS-200 to determine and store a modem's configuration, and to send a chosen configuration to the Redundant Modem.

IF switching is distributed - each Modem has an internal RF relay, which is normally under the control of the Modem's internal software. However, there is a direct hardware connection that over-rides the processor setting, and turns the carrier off. All the transmit outputs of the modems are connected to a passive IF combiner, and the IF outputs from a Traffic or Redundant Modem can be enabled or disabled via a hardware command from the CRS-200. For the receive IF, all of the Traffic Modems, and the Redundant Modem are fed with identical signals from a passive IF distribution system. In this way, the Redundant Modem can demodulate any of the input carriers going to the Traffic Modems.

The data and clock signals, to and from a Traffic Modem, are routed through a Traffic Modem Interface (TMI), via a set of relays. This is arranged so that the de-energised (unpowered) state connects the data signals directly through to the Traffic Modem. If the power supplies to the system are lost, or if a TMI carrying traffic is removed, no interruption of the traffic will take place. It should also be noted that in normal circumstances, where the Redundant Modem is not in service, no data is carried through the CRS-200 backplane - all data is routed via the TMI.

A key feature of the CRS-200 architecture is its ability to let the Redundant Modem 'bridge' a Traffic Modem. A copy of the data and clock signals feeding a particular Modem can be selectively routed to the Redundant Modem, and the RX IF can be tuned to receive any selected carrier. This has the advantage that no external test equipment is needed to determine the health of the Redundant Modem - live traffic is used at all times to verify performance.

The CRS-200 is fully modular in construction. All replaceable modules insert into slots in the rear. This includes the Controller, PSU's, TMI's and the RMI. Power consumption is below 25 watts for a fully populated Switch, and hence no fan cooling is required.

Connection to the Traffic Modems and the Redundant Modem is remarkably simple - a single cable is required for each modem, which carries all data signals, alarm information, and remote control interfaces. This simplifies rack cabling, and reduces the number of potential failure points.



## 4 PHYSICAL DESCRIPTION

The CRS-200 is constructed as a 4U high rack-mounting chassis, that can be free-standing, if desired. It is provided with rack-handles at the front to facilitate its removal from, and placement into a rack.

### 4.1 FRONT PANEL - See Figure 1

On the front panel of the unit are the Vacuum Fluorescent Display (VFD), keypad, and several LED indicators. The user enters data via the keypad, and messages are displayed on the VFD. Behind the front panel there is also an audio alarm, that can be controlled to respond to various faults.

The Vacuum Fluorescent Display (VFD) is an active display showing 2 lines, each of 24 characters. It produces a pleasing blue light, the brightness of which can be controlled by the user. It has greatly superior viewing characteristics compared to a Liquid Crystal Display (LCD), and does not suffer problems of viewing angle or contrast.

The keypad comprises six individual keyswitches, mounted directly behind a fully sealed membrane overlay. They have a positive 'click' action, which provides the user with tactile feedback. These six switches are identified as UP ARROW, DOWN ARROW, RIGHT ARROW, LEFT ARROW, ENTER and CLEAR. The functions of these keys are described in the 'Front Panel Operation' section.

There are 3 LED indicators at the top of the front panel that reflect the condition of the switch itself. The functions of these indicators are shown in Table 1 below.

**TABLE 1 - SWITCH LED INDICATORS**

LED	Color	Condition
Unit Status	Red	A Switch Fault exists (Example: PSU fault)
	Green	No Switch Faults
Stored Event	Off	There are no Stored Events
	Orange	There are Stored Events, either for the switch itself or the modems attached to it
Remote	Off	The Switch is in Local Mode - remote monitoring is possible, but no remote control
	Orange	The Switch is in Remote Mode - control changes are disabled via the front panel keypad

There are 5 LED indicators for each of the 10 TMIs that may be plugged into the rear of the switch, and 4 of the 5 are repeated an eleventh time for the RMI. These are described in Table 2 below.

**TABLE 2 – MODEM LED INDICATORS**

LED	Color	Condition
<b>Unit Status</b>	Red	A Unit Fault exists
	Orange	No Unit Faults, but a Traffic Fault exists <b>OR</b> the TMI is not plugged in
	Green	No Unit Faults, or Traffic Faults
<b>Transmit Traffic</b>	Green	No Tx Traffic Faults
	Off	A Tx Traffic fault exists <b>OR</b> the TMI is not plugged in
<b>Receive Traffic</b>	Green	No Rx Traffic Faults
	Off	An Rx Traffic fault exists <b>OR</b> the TMI is not plugged in
<b>On line</b>	Green	The Unit is On Line, and carrying traffic
	Off	The Unit is Off Line (standby) - forced by the Switch
<b>Bridged</b>	Orange	Modem is currently being Bridged by Redundant Modem
	Off	Modem is not being Bridged

The last indicator is not repeated for the redundant modem, since it cannot bridge itself.

#### 4.2 REAR PANEL - see Figure 2

External cables are attached to connectors on the rear panel of the CRS-200's plug-in modules. These comprise the IEC line input connectors, the Data connectors to each modem, the User Data Interface connector for each traffic modem to the outside world, the System Alarms connector, the Remote Control connector, and Auxiliary RS-485 connector.

The IEC line input connector for each Power Supply Module contains the ON/OFF switch for that module. It is also fitted with two fuses - one each for line and neutral connections (or L1, L2, where appropriate). These are contained within the body of the connector, behind a small plastic flap.

For 230 volt AC operation, use T0.5A, (slow-blow) 20mm fuses.

For 115 volt AC operation, use T1A fuses, (slow-blow) 20mm fuses.

**FOR CONTINUED OPERATOR SAFETY, ALWAYS REPLACE THE FUSES WITH THE CORRECT TYPE AND RATING.**

The Data connectors on the TMI plug-ins are 25 pin 'D' type male leading to/from the modems, and female leading to/from the outside world (User Data). These conform to the EIA 530 pinout, which allows for connection of different electrical standards, including RS422, V.35, and RS232. Please note that it is the responsibility of the user to provide the appropriate cables to connect to these EIA 530 connectors. A shielded 25 pin 'D' type provides a very solid solution to EMC problems, unlike the V.35 Winchester connector. The male connector to/from the modem requires a simple pin-to-pin cable with connectors of opposite sex so that the other end can plug into the modem's Data connector. The female connector can then be treated as an extension of the traffic modem's Data connector. The RMI has no User Data connector since it will only replace one of the traffic modems. The pinout for both connectors is provided in the next section.

The System Alarms connector on the System Controller card is another 25 pin female D-sub. This provides the user with access to Form-C relay contacts that indicate the fault status of the switch and the summary faults for the three modem alarm types. If *any* of the attached modems has one of the three faults active, the corresponding relay will energize, forcing the normally open pin to connect to (and the normally closed pin to disconnect from) the common pin. There are also relay contacts to indicate which, if any, of the traffic modems is currently being backed up. Another pin provides a ground connection when the audio alarm is sounded so that additional sounders may be added by the user. The pinout details for this connector are provided in the next section.

The IF Switch Control connector is a 25 pin male D-sub that should be cabled directly to the corresponding connector on the CRS-280 Transponder Switch, if used. This not only supplies power to the CRS-250, but also indicates the currently selected traffic modem and whether the system is in bridged or back-up mode. The CRS-280 must perform the same bridging and backing up functions to the transmit and receive IF signals to match what the CRS-200 does to the terrestrial data signals. The pinout of this connector is provided in the next section.

The Remote Control connector is a male 9 pin D-sub. Access is provided to remote control ports of the switch, both RS232 and RS485. The pinout details for this connector are provided in the next section.

The Auxiliary Serial connector is another 9 pin D-sub, this one female. It is currently unused, but is reserved for use as an additional RS-485-only remote link that may be added on future revisions of the switch.



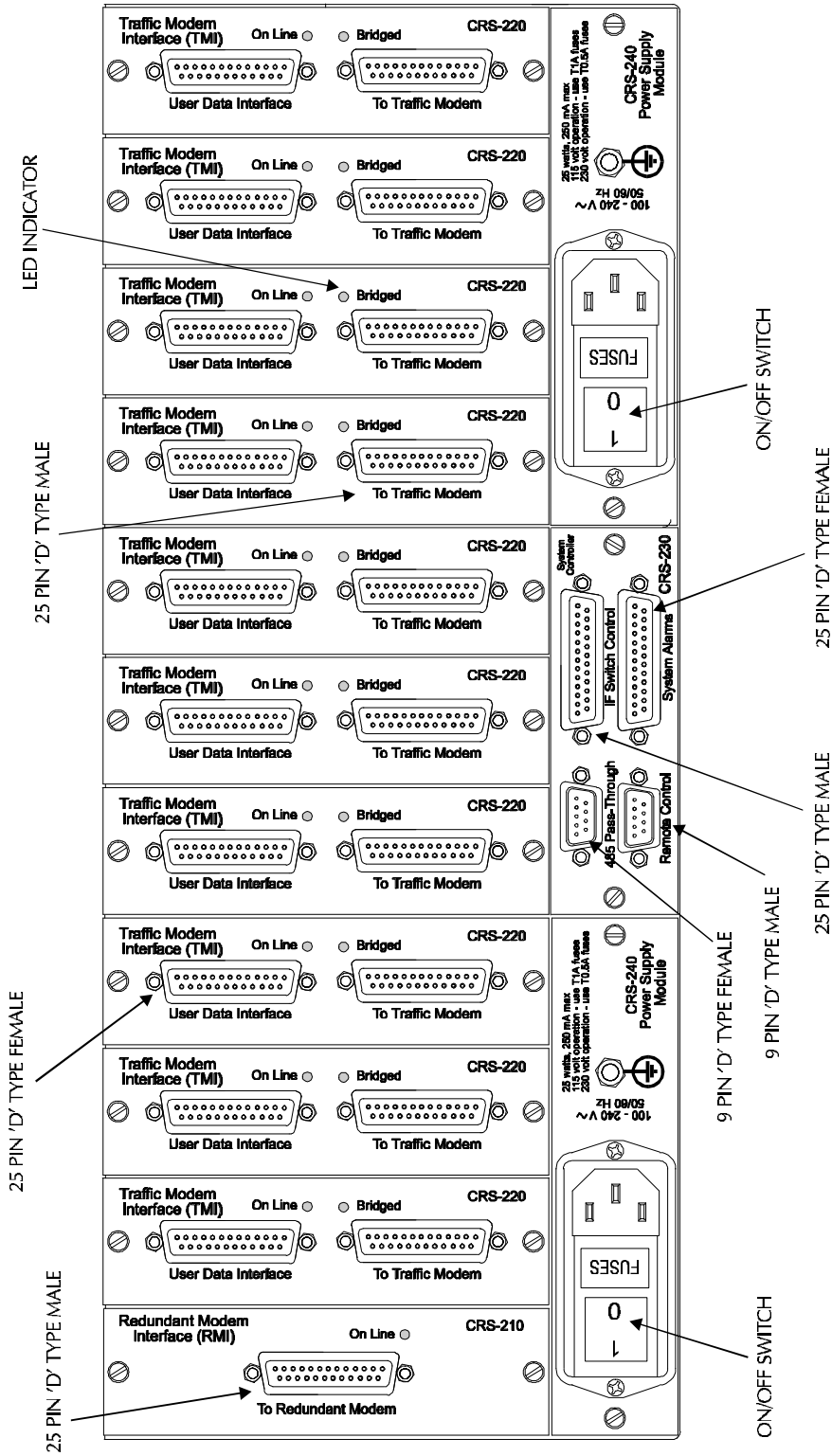

FIGURE 2 CRS-200 REAR PANEL

## 5 FUNCTIONAL DESCRIPTION

The CRS-200 is a 1-for-N redundancy controller, meaning that a single redundant modem (referred to as an RM) can be employed as a backup in the event of a failure to any one of up to 10 traffic modems (referred to as a TM). An overall system is shown in **Figure 3**. The front panel includes system status LEDs that indicate the current fault status of all the modems connected to the switch. In addition, there are LEDs for the modems' online status and, for the traffic modems, an indication of which modem is currently being "bridged" by the redundant modem. This means that the redundant modem has been programmed to match the configuration of that selected traffic modem, and is being fed with a copy of the traffic signals that the TM sees.

In addition to the main chassis, there are 4 different types of plug-in units, all of which are fastened at the rear of the chassis using hand-tightened captive screws. These are the Redundant Modem Interface (CRS-210), of which one is required in the leftmost slot while looking at the rear of the chassis; the Traffic Modem Interface (CRS-220), of which one is needed for each traffic modem to be used and can occupy any of the other ten slots; the System Controller (CRS-230), of which one is required; and the Power Supply Module (CRS-240), for which 2 slots are provided so that the switch can operate with either/both installed.

The Redundant Modem Interface (RMI) card has a single 25-pin male D-sub connector that is attached to the redundant modem's primary data connector with a shielded cable. This connection between the RMI and the redundant modem includes fault relay status from the modem to the switch as well as an RS-232 remote control link, so that no other interconnections are required. Transmit terrestrial signals normally sent to the bridged traffic modem are also routed to the redundant modem through this connection. When the redundant modem is put online, all terrestrial signals from the redundant modem replace those of the traffic modem that was taken offline. An online LED is also present that matches the corresponding Redundant Modem Online indicator on the switch's front panel.

Each traffic modem is connected to the switch by its Traffic Modem Interface (TMI) card. The same type of 25-pin cable used on the RMI should be used to connect the TMI to the traffic modem's primary data connector, again with fault status and RS-232 remote link included. A second connector on the TMI (this one female) serves as the terrestrial data interface. The TMI modules are designed so that they may be inserted or removed while the switch is turned on, without causing interruptions to the data traffic. The TMIs also have a rear Online LED, as well as a Bridged LED that also matches the front panel version. Any switch that is ordered with fewer than 10 TMI cards will have blank plates installed in place of TMI cards in the last unused slots.

The System Controller card is the heart of the switch, containing a 16-bit microcontroller, flash-upgradable PROM and non-volatile memory. In addition to a 9-pin D-sub connector (male) for remote communication between the switch and a PC in either RS-232 or RS-485 format, the System Controller also has a 25-pin connector (male) for interfacing the switch to the Comtech IF transponder switch, a 25-pin connector (female) for switch and modem alarm relay outputs and another 9-pin (female) connector that is reserved for a possible auxiliary RS-485 remote link.

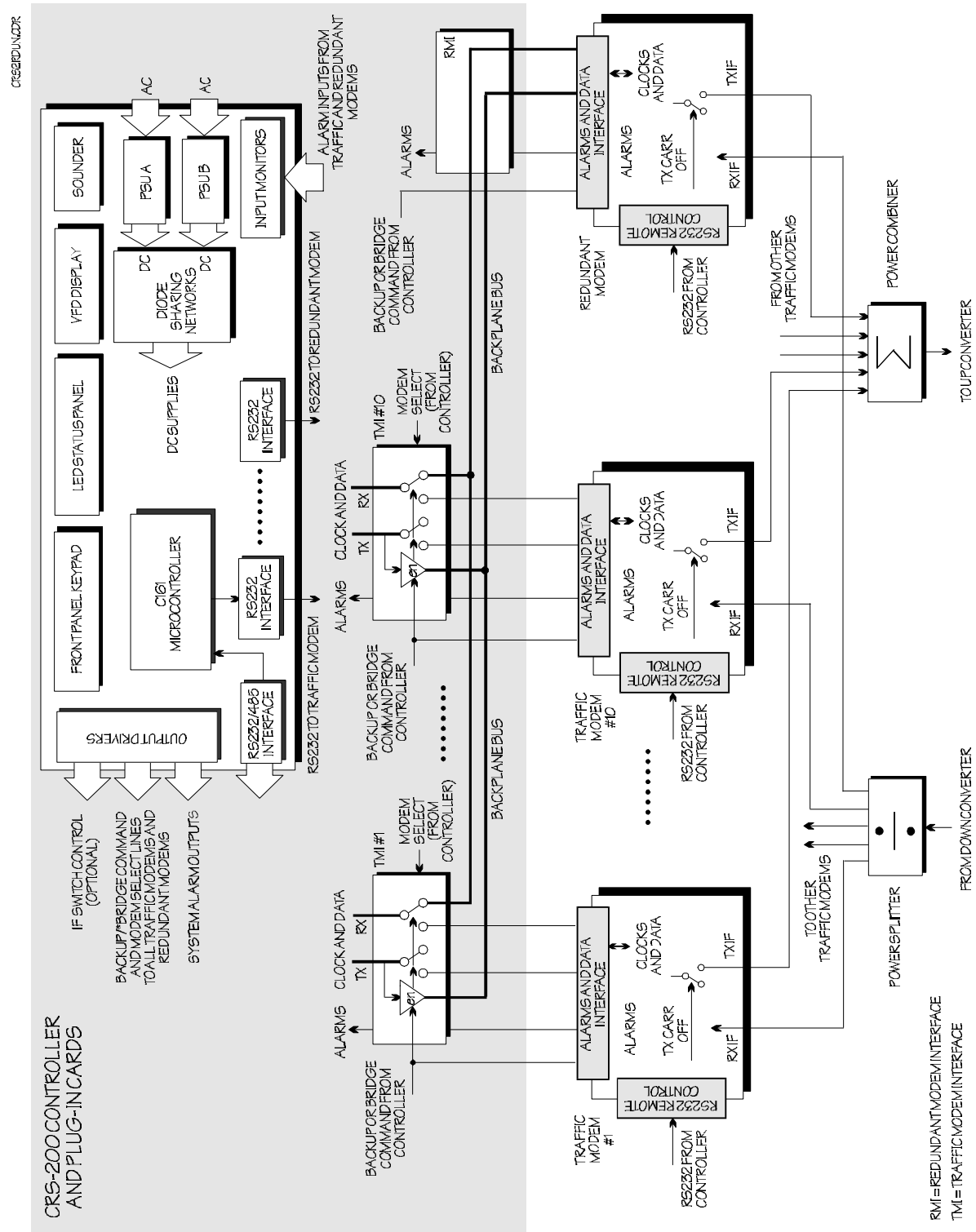

FIGURE 3 CRS-200 - REDUNDANCY SCHEME - SINGLE UP/DOWN CONVERTER

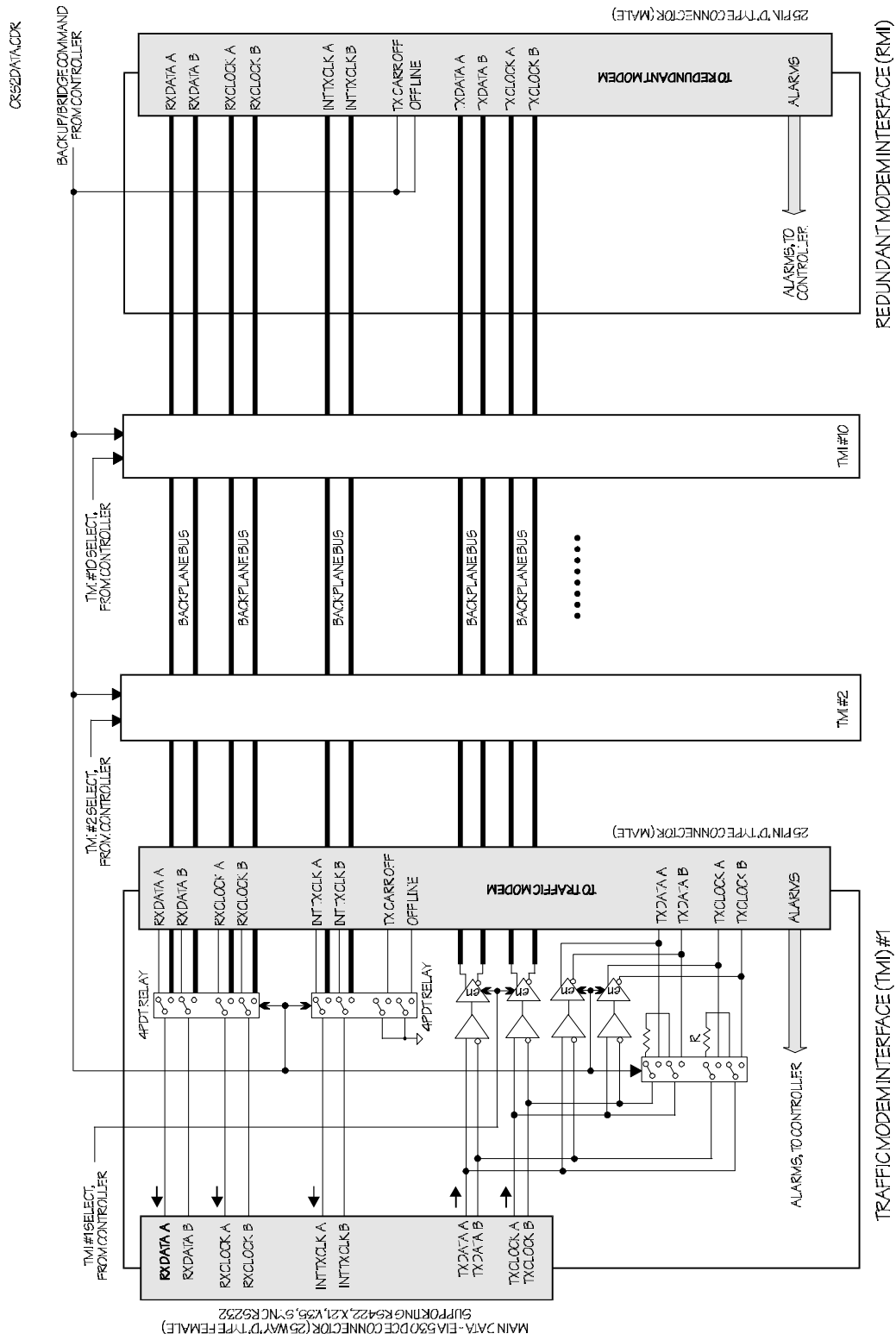

FIGURE 4 CDS-200 - DATA SWITCHING DETAILS



A CRS-240 Power Supply Module is installed in each side of the chassis. If one module is removed while power is on, the system continues to operate with no disturbance. This allows servicing of a module without interruption. The controller monitors the +5V, +12V and -12V supplies of each module separately, and any fault reported on either module can be masked if the user chooses to operate without a backup in place. Module A is on the right and Module B is on the left as viewed from the rear of the chassis.

The microcontroller in the CRS-200 continuously scans the system to gather information. This information is then used to determine if action needs to be taken. Every second, three status checks are performed. First, all 11 modem interface positions are checked in succession for the presence of an interface card and, if present, all three modem alarm relay conditions are checked. If a modem interface is present but no modem is connected with the 25-pin cable, all three fault indicator LEDs on the front panel will show the faulted state. Unmasked faults are logged.

Second, the switch checks itself for faults. These consist of either power supply faults or a failure to communicate remotely with the redundant modem, and are also logged if unmasked. The outputs of both power supplies are monitored for both overvoltage and undervoltage conditions, but only one supply may have its faults masked at a time. A remote communication fault with the redundant modem may not be masked, since the switch requires this to operate. Both modem and switch alarms also cause an update to the switch's own relay outputs on the rear panel of the System Controller card.

Third, one of the 11 modems is checked for a configuration change on each one second interval. So, over an 11 second period, any change made to a modem either remotely or via the front panel will automatically cause an update to that modem's configuration which is stored in the switch's memory. If the switch has been in operation with a modem or its TMI is missing, so that it has never saved a configuration for that position, that position is not allowed to become activated. The switch, however, continues to check the unoccupied position at each pass, so that adding a modem later will result in a configuration being found by the switch and the modem position may then be activated. If a modem is removed or fails such that communication is lost, the last stored configuration remains in the switch's memory.

After each one second status check, the switch uses the current status information in conjunction with its own configuration to decide to "backup" or "bridge". When the redundant modem "bridges" a particular traffic modem, the redundant modem is re-configured to match the selected traffic modem using the stored configuration, and is fed with a copy of the traffic modems signals. To "back-up" that traffic modem, a series of relay changes on the selected TMI puts the redundant modem online in place of the traffic modem. In both cases, the RM and the selected TM are in parallel with each other, meaning that transmit terrestrial signals are sent to both modems simultaneously. By virtue of being set to the same receive parameters (such as IF frequency and data rate) and being cabled together, their demodulators will lock to the same signal. **Figure 4** shows how the data paths change when a traffic modem is taken offline in place of the redundant modem. When a configuration change occurs to either the bridged TM or the RM itself, the switch will automatically reconfigure the RM to match the TM it is bridging.

## 6 CONNECTOR PINOUTS

### 6.1 DATA CONNECTOR - 25 PIN 'D' TYPE MALE AND FEMALE

Pin	Generic Signal description	Direction	RS422/ EIA 530	V.35	RS232	Circuit No
2	Transmit Data A	DTE to Modem	SD A	SD A	BA	103
14	Transmit Data B	DTE to Modem	SD B	SD B	-	103
24	Transmit Clock A	DTE to Modem	TT A	SCTE A	DA	113
11	Transmit Clock B	DTE to Modem	TT B	SCTE B	-	113
15	Internal Transmit Clock A	Modem to DTE	ST A	SCT A	DB	114
12	Internal Transmit Clock B	Modem to DTE	ST B	SCT B	-	114
3	Receive Data A	Modem to DTE	RD A	RD A	BB	104
16	Receive Data B	Modem to DTE	RD B	RD B	-	104
17	Receive Clock A	Modem to DTE	RT A	SCR A	DD	115
9	Receive Clock B	Modem to DTE	RT B	SCR B	-	115
8	Receiver Ready A	Modem to DTE	RR A	RLSD *	CF	109
10	Receiver Ready B	Modem to DTE	RR B	-	-	109
23	External Carrier Off (RS232 '1' or TTL 'low' )	DTE to Modem	-	-	-	-
7	Signal Ground	-	SG	SG	AB	102
1	Shield	-	Shield	FG	AA	101

#### NOTES:

\* Receiver ready is an RS232-level control signal on a V.35 interface

**DO NOT** connect signals to pins which are not shown - these pins are reserved for use by the redundancy system

'B' signal lines are not used for RS232 applications

For X.21 operation, use the RS422 pins, but ignore Receive Clock if the Modem is DTE, and ignore Transmit clocks if the Modem is DCE

## 6.2 SYSTEM ALARMS CONNECTOR - 25 PIN 'D' TYPE FEMALE

Pin	Description
7	Ground
21	Switch Unit Fault – Normally Open
9	Switch Unit Fault – Normally Closed
22	Modem Summary Unit Fault - Normally Open
10	Modem Summary Unit Fault - Normally Closed
23	Modem Summary Tx Traffic Fault – Normally Open
11	Modem Summary Tx Traffic Fault – Normally Closed
24	Modem Summary Rx Traffic Fault – Normally Open
12	Modem Summary Rx Traffic Fault – Normally Closed
8	Form-C Fault Relay Common
6	Backup Traffic Modem #1 – Normally Open
18	Backup Traffic Modem #2 – Normally Open
5	Backup Traffic Modem #3 – Normally Open
17	Backup Traffic Modem #4 – Normally Open
4	Backup Traffic Modem #5 – Normally Open
16	Backup Traffic Modem #6 – Normally Open
3	Backup Traffic Modem #7 – Normally Open
15	Backup Traffic Modem #8 – Normally Open
2	Backup Traffic Modem #9 – Normally Open
14	Backup Traffic Modem #10 – Normally Open
1	Backup Traffic Modem Common
20	Audio Indicator (Gnd = Audio on, Float = Audio off)
25, 13, 19	No Connection
<b>Note: Normally Open refers to the NON-FAIL state</b>	

### 6.3 IF SWITCH CONTROL CONNECTOR - 25 PIN 'D' TYPE MALE

Pin	Description
16	Modem Select 0 (to IF Switch) *
4	Modem Select 1 (to IF Switch) *
17	Modem Select 2 (to IF Switch) *
5	Modem Select 3 (to IF Switch) *
8	Bridge/Backup Indicator (to IF Switch)
21	IF Switch Present (active high from IF Switch)
10, 22	Fused +5V Supply
12, 24	Fused +12V Supply
11, 13, 23, 25	Ground
1, 2, 3, 6, 7, 9, 14, 15, 18, 19, 20	No Connection

\* **Note:** Modem Select 0-3 represent the binary address of the modem.

### 6.4 REMOTE CONTROL CONNECTOR - 9 PIN 'D' TYPE MALE

Pin	Description
1	Ground
5	Ground
9	RS485 Transmit Data A
8	RS485 Transmit Data B
7	RS485 Receive Data A
6	RS485 Receive Data B
2	RS232 Transmit Data
3	RS232 Receive Data
4	Reserved - do not connect to this pin

## **7 INSTALLATION**

### **7.1 UNPACKING**

Inspect shipping containers for damage. If shipping containers are damaged, they should be kept until the contents of the shipment have been carefully inspected and checked for normal operation.

Remove the packing list from the outside of the shipping carton. Open the carton and remove the contents, checking the contents against the packing list. Verify completeness of the shipment and that the unit functions correctly. If damage is evident, contact the carrier and Comtech immediately and submit a damage report. Be sure to keep all shipping materials for the carrier's inspection.

If the unit needs to be returned to Comtech Communications, please use the original shipping container.

### **7.2 MOUNTING**

The CRS-200 will typically be mounted in a rack along with all the modems with which it is to operate, so it is important to ensure that there is adequate clearance for ventilation. The limit is four modems, and then a blank 1U panel must be inserted to allow sufficient airflow around the units. Since the switch itself is relatively passive, no additional clearance is needed between it and the nearest modems. In rack systems where there is high heat dissipation, forced air cooling should be provided by top or bottom mounted fans or blowers. Under no circumstance may the highest internal rack temperature be allowed to exceed 50°C. The CRS-200 has not been designed to have rack slides mounted to the side of the chassis. However, Comtech recommends that some method of support within the rack should be employed, such as rack shelves, or a rear support bracket. If the user is any doubt, please consult the factory.

### **7.3 CONFIGURATION**

All of the equipment within the system needs to have the appropriate cables attached, and then be properly configured. This is covered in the next section – SETUP GUIDE.

## 8 SETUP GUIDE

Once the switch and all the modems have been mounted, the user must properly attach all required cabling and configure the system for correct operation. What follows is a step by step description of this process. Please leave the switch and all modems powered off until all connections are ready.

### **WARNING**

#### **DO NOT MIX MODEM TYPES IN THE SWITCH.**

For the CRS-200 to operate correctly, identical modem types must be used for all traffic modems, and the redundant modem. As an example, it is not permissible to have a mixture of CDM-500 and CDM550T modems within the same redundancy switch group.

### **IMPORTANT NOTE**

For correct operation of the CRS-200, the Modems must have the following Firmware versions installed:

**CDM-500 - Version 1.18 or later**

**CDM-550 - Version 1.15 or later**

**CDM-550T - Version 1.10 or later**

If the modems do not meet this requirement, please contact the factory to arrange for a free upgrade to be sent to you.

### 8.1 25-PIN DATA CABLES

First, connect all 25-pin cables between the modems and their appropriate TMI or RMI cards. It is important that all modems be of the same model number and software revision so that the redundant modem can properly mimic all traffic modems. If there are unused positions on the switch, remove any unused TMI cards and replace with a blank plate.

#### 8.1.1 PHYSICAL CABLE REQUIREMENTS

The 25-pin cables required between each modem and its plug-in card (TMI or RMI) should be of shielded, twisted-pair construction with the grounded shield bonded to the back-shell. All 25 pins should be wired to the same pin number at either connector (pin-to-pin), with a male connector at one end and female at the other (**SEE CABLES SECTION**). The modem accepts the male end of the cable while the TMI or RMI accepts the female end into the port labeled "To Traffic Modem" or "To

Redundant Modem". Depending upon the location of each modem in the rack, a length of from 2 to 5 feet is desirable. Appropriate data cables are available from Comtech, so please consult the factory for ordering information. Please note that these cables are an extra-cost item.

### **WARNING**

#### **ALWAYS KEEP THE 25-PIN CABLE ATTACHED TO AN OPERATING SWITCH WHILE POWER IS SUPPLIED TO THE MODEM.**

If a modem is added to an operating 1:N system, attach its cable before applying power. If a modem is removed, turn off power first, then remove its 25-pin cable. This allows the switch to always have control of a modem's Tx carrier, and prevent contention in the system.

#### **8.1.2 EXTERNAL DATA CONNECTION**

When each cable is connected between the modem and its plug-in card, the user's terrestrial data connection to the external router, multiplexing equipment or test data generator should be made to the female connector on the TMI labeled "User Data Interface". This replaces the direct connection to the traffic modem's "Data Interface" port. Note that the RMI does not have this connector, as the redundant modem's function is to replace a faulted traffic modem. Even with the switch turned off, this should complete the terrestrial data paths between each traffic modem and its external equipment so that the modems may now be switched on.

NOTE TO USERS OF THE CIC-50: If a modem requires Comtech's optional G.703 Interface Converter, the CIC-50, the device must plug into the TMI's "User Data Interface" port, rather than directly to the rear of the modem. Unfortunately, space limitations require that another 25-pin cable be attached between the TMI and the CIC-50. The redundant modem does not require its own converter.

#### **8.1.3 REMOTE CONTROL**

With power applied to all modems, it is important to set all their remote interfaces to **RS232** with a **baudrate of 9600**. This is the default configuration for all Comtech modems. All modems **remain at address 0000** because the switch communicates with the desired modem via hardware. This connection is made on the 25-pin cable using pins that are not used by the terrestrial data paths. **Because the remote link for all the modems is accomplished through the 25-pin cables, it is important to leave the 9-pin remote connectors unplugged to avoid contention.**

**IMPORTANT REMINDER:**

SET THE REMOTE CONTROL INTERFACE ON **ALL** OF THE MODEMS  
IN THE REDUNDANCY GROUP TO **RS232, 9600 BAUD**

THE REDUNDANT MODEM **MUST** BE IN REMOTE MODE

THE TRAFFIC MODEMS CAN BE IN LOCAL OR REMOTE MODE  
(PUT INTO REMOTE MODE IF REMOTE M&C THROUGH THE  
SWITCH IS REQUIRED)

DO NOT BE CONCERNED THAT ALL THE MODEMS ARE SET TO  
ADDRESS 0000 - THE SWITCH TRANSLATES ADDRESSES AND PASSES  
COMMANDS TO THE CORRECT MODEMS

Next, set the redundant modem to remote mode. The traffic modems may be left in local or remote mode, depending on how the user wishes to communicate with them, but the redundant modem must always be set to remote mode. This is because the switch must always be able to control its configuration. A failure by the switch to control the redundant modem remotely is considered a fault condition.

**8.1.4 MODEM ALARMS**

In addition to the remote link, the 25-pin cable also carries the modem's alarm relay outputs, which are repeated on the 15-pin alarm connector. An input line, "External Carrier Off", is also present on both connectors. Since this input is used by the switch to control the modems' IF carriers by driving this line, it is recommended that the 15-pin port on the modem should be used with caution.

**8.2 INITIAL CRS-200 SETUP**

With the terrestrial cabling complete and the modems powered on, but the modems' IF ports still unconnected, apply power to the CRS-200 and perform an initial configuration as described next.

**8.2.1 POWER SUPPLY MODULES**

The auto-sensing AC power supplies do not require any adjustments. Simply plug in the supplied line cords and turn on the switches on the rear panel. Each CRS-200 is shipped with two supplies, and it is recommended that both be used for maximum



reliability. If the redundant modem has been set to remote mode, as specified earlier, applying power to both modules should result in the switch showing a green Unit Status fault. If the user must operate with only one power supply module, the unused position may have its faults masked by going to the "CONFIG, OPTIONS, ALARM-MASK, SW-ALARMS" menu and selecting that supply.

### 8.2.2 BASIC SWITCH CONFIGURATION

There are no internal jumpers to configure, and no other options to install. All configuration is carried out entirely in software. The unit should first be configured locally, using the front panel keypad and display. The unit will ship with a default configuration that has traffic modem #1 as the currently bridged, and only active, modem and the switch itself in Manual operating mode. It is the Manual (rather than Auto) setting which causes the Stored Event LED to blink as a warning to the user.

Go to the "MONITOR, TM-CONFIGS" menu, and verify that all traffic modems have been queried by the switch as to their current configurations. These are stored in the switch's memory for use in re-configuring the redundant modem. At this time, the user should activate all desired traffic modems by using the "CONFIG, OPTIONS, ACTIVE-MODEMS" menu.

The other LEDs are arranged in columns corresponding to each modem, and should accurately reflect the alarm status of each. There is also an "online" indicator for each modem, which should be lit for all traffic modems and extinguished for the redundant modem, and a "bridged" indicator which should be illuminated for traffic modem #1 only. Note that the switch forces the redundant modem offline, since its Tx Traffic LED is extinguished (even though it has no transmit alarm).

### 8.3 IF CABLES AND TRANSPONDER SWITCH

Next, the IF carriers of all the modems must be configured. There are two options as to how these are to be handled. The transmit IF carriers from all the modems may be combined and sent to a single upconverter, or each modem may be associated with its own transponder. The setup for these two options are described next.

#### ***IMPORTANT NOTE***

Comtech does not supply IF cables or IF splitters/combiners with the CRS-200 Redundancy Switch. It is the responsibility of the User to furnish these items.

### 8.3.1 SINGLE TRANSPONDER

If all modems are to be connected to the same transponder, it is necessary at this time to configure each modem's transmit side to the proper data rate, IF frequency and output power level. Once this is done, the user must combine these carriers together using BNC cables into a single power combiner. The output of the combiner is then fed to the upconverter. Both the cables and the combiner must be the same impedance as the modems to prevent mismatch.

On the receive side, the output of the downconverter must be attached by BNC cables to a single splitter which in turn feeds all the receive IF ports of the modems.

When a traffic modem is taken offline, its transmit IF will automatically shut down and be replaced by that of the redundant modem so that no interference occurs.

### 8.3.2 MULTIPLE TRANSPONDERS USING CRS-280 TRANSPONDER SWITCH

If, on the other hand, each modem is to be connected to its own transponder, then the system requires the Comtech CRS-280 Transponder Switch. This connects to the CRS-200 with a 25-pin control cable. Transmit and receive BNC cables connect to the modems in use. The CRS-200 automatically senses the presence of the CRS-280 so that the CRS-200 will no longer suppress the transmit IF output of the offline modem (Tx Traffic LED stays on). Instead, the Transponder Switch will switch the redundant modem's IF in place of the traffic modem being taken offline. This arrangement is shown in **Figure 5**.

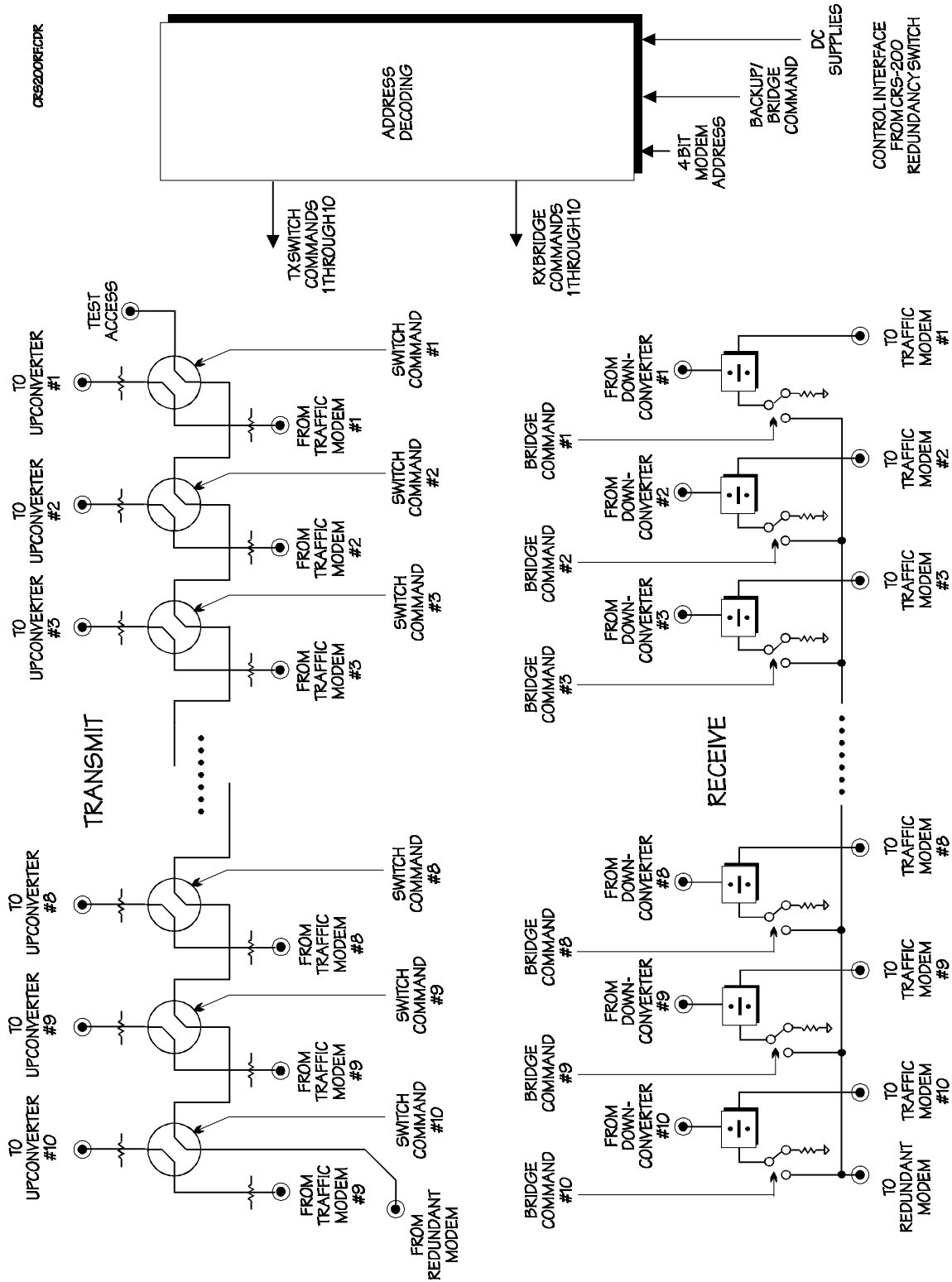

FIGURE 5 CRS-280 - TRANSPONDER SWITCH - EXTERNAL MODULE, IF REQUIRED

## 8.4 ADDITIONAL SWITCH CONFIGURATION

Once all IF cabling is complete, the system should be completely operational but still in Manual mode. The user may choose to operate in this manner, but the switch will not automatically react to traffic modem failures it detects. If the system is to be left unattended, it is recommended that the user go to the "CONFIG, AUTO" menu and turn on Auto mode. The Stored Event LED will stop blinking, and now the switch will force the redundant modem to bridge, then back up the first *activated* modem which fails. Two other configuration options are useful for fine tuning the switch's Auto mode, and are described next.

### 8.5.1 HOLDOFFS

When in Auto mode, additional delays may be introduced to the backup procedure by going to the "CONFIG, OPTIONS, HOLDOFFS" menu and changing the "backup holdoff" from its default of 5 seconds to anywhere from 2 to 99 seconds. When a traffic modem fails and the redundant modem is forced to "bridge" it, the switch waits this length of time to determine two things: does the traffic modem remain faulted, and is the redundant modem not exhibiting the same fault? If the answer to both questions is "yes" for the entire holdoff time, the switch performs the actual backup.

The "restore holdoff", which is also programmable from 2 to 99 seconds, determines the switch's ability to automatically put a backed up traffic modem online again if its fault goes away. Normally, a failed modem that was taken offline will remain offline indefinitely even in Auto mode unless another traffic modem fails. In this case, the originally failed modem will be put back online by the switch if its fault has been clear for the full programmed restore holdoff time. The redundant modem can then be used to backup the newly failed modem. The switch has no prioritization scheme, so that multiple traffic modem failures are treated on a 'first come, first serve' basis only.

### 8.5.2 ALARM MASK

Another way to adjust the switch's reaction in Auto mode is to mask modem faults. Under "CONFIG, OPTIONS, ALARM-MASK, MODEM-ALARMS", the user may disable Tx, Rx or both faults from being seen by the switch. This not only prevents the switch from taking automatic action, but also keeps the faults from being logged on its stored events list. Note that these masks are global to all the modems attached to the switch. Note also that each modem can be individually programmed with its own set of alarm masks.

#### **NOTE**

Please read this Operations Manual in conjunction with the Operations Manual for the CDM-500, CDM-550, or CDM-550T as details of the operation of the Modem equipment is not covered in this document.

## 9 FRONT PANEL OPERATION

### 9.1 DESCRIPTION

The user can fully control and monitor the operation of the CRS-200 from the front panel, using the keypad and display. Nested menus are used, that display all available options, and prompt the user to carry out a required action.

The display has two lines each of 24 characters. On most menu screens, the user will observe a flashing **solid block cursor**, which blinks at a once-per-second rate. This indicates the currently selected item, digit, or field. Where this solid block cursor would obscure the item being edited (for example, a numeric field) the cursor will automatically change to an **underline cursor**.

If the user were to display the same screen for weeks at a time, the display could become 'burnt' with this image. To prevent this, the unit has a 'screen saver' feature that will activate after 1 hour. The top line of the display will show the Switch ID (which can be entered by the user) and the bottom line will show the current status of the switch followed by 'Press any key....'. The message moves from right to left across the screen, then wraps around. Pressing any key will restore the previous screen.

The keypad has six keys, the functions of which are described below:

RIGHT ARROW	Moves the cursor to the right, when it is displayed
LEFT ARROW	Moves the cursor to the left, when it is displayed
UP ARROW	Used for editing the value at the current cursor position, if appropriate. If this is a numeric field, this will increment the value.
DOWN ARROW	Used for editing the value at the current cursor position, if appropriate. If this is a numeric field, this will decrement the value.
ENTER (ENT)	Used to accept an edited entry. Most menus prompt the user to press this key, by displaying the text ( <b>PRESS ENTER</b> ), ( <b>ENTER</b> ) or ( <b>ENT</b> ). This results in the entry being accepted, and the user is then returned to the previous menu.
CLEAR (CLR)	Used to escape from the current operation and return to the previous menu.

**IMPORTANT NOTE:** The keypad has an **auto-repeat** feature. If a key is held down for more than 1 second, the key action will repeat, automatically, at the rate of 15 keystrokes per second. This is particularly useful when editing numeric fields.

## 9.2 MENU TREE

**Figure 6** shows the menu structure of the CRS-200. The detailed screens and menus will now be described.

Note: The 'level' of the menu (how far down into the structure) is indicated by how far the screen is indented from the left.

### OPENING SCREEN

```
COMTECH CRS-200 SWITCH
S/N 1020    S/W VER 1.01
```

This screen is displayed whenever power is first applied to the unit. Pressing any key will take the user to the top level selection screen:

### SELECT

```
SELECT:    CONFIG    INFO
MONITOR    STORE/LD   UTIL
```

The user is presented with the following choices:

- |          |  |
|----------|--|
| CONFIG   | (Configuration) This menu branch permits the user to fully configure the switch.   |
| INFO     | (Information) This menu branch permits the user to view information on the switch, without having to go into configuration screens.                                    |
| MONITOR  | (Monitor) This menu branch permits the user to monitor the current status of the switch and view the log of stored events for both the switch and its attached modems. |
| STORE/LD | (Store/Load) This menu branch permits the user to store and to retrieve up to 10 different switch configurations.  |
| UTIL     | (Utility) This menu branch permits the user to perform miscellaneous functions, such as setting the Real-time clock, adjusting the display brightness, etc.            |

Each of these options is now described in detail.

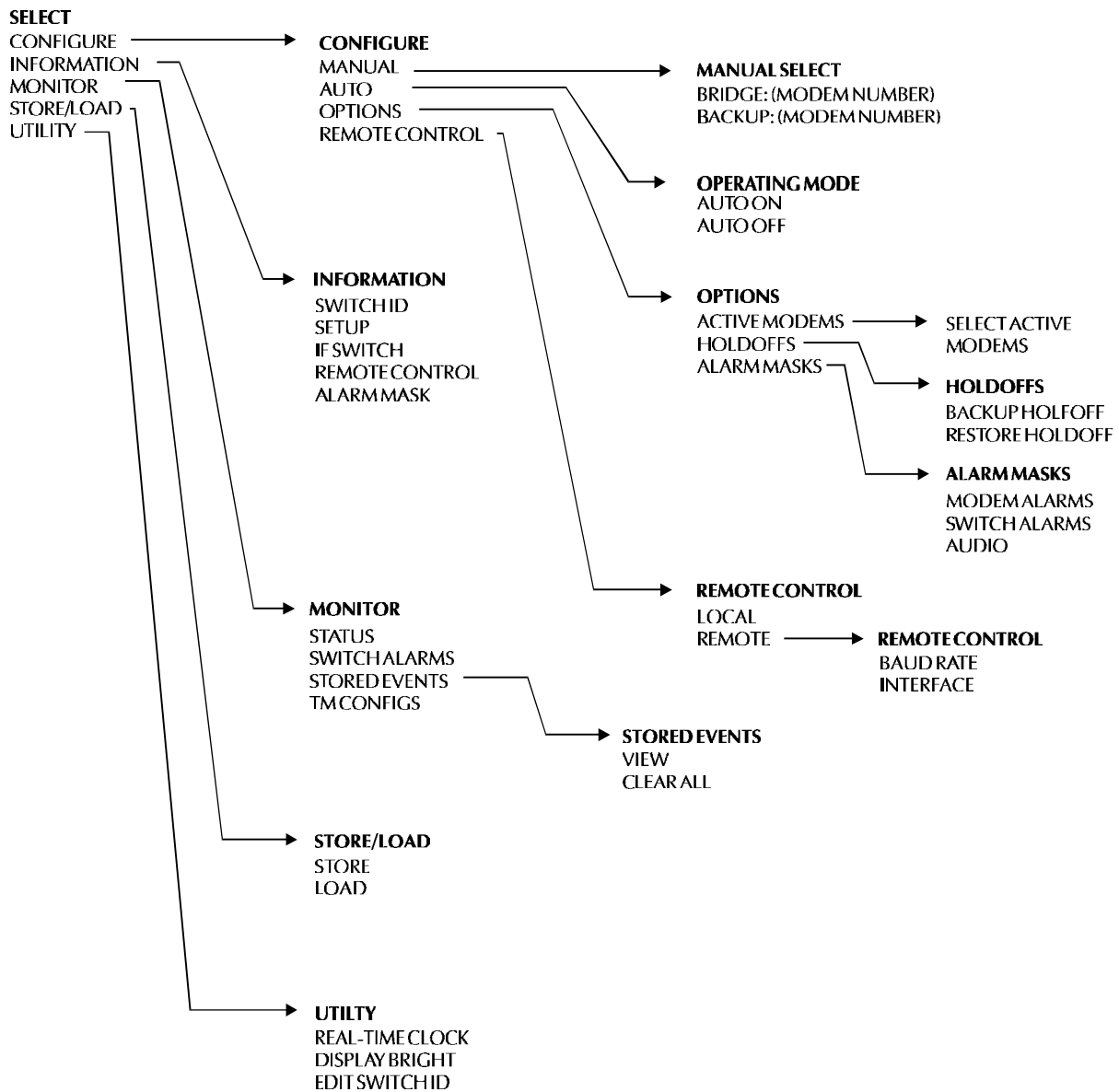

FIGURE 6 CRS-200 PRINCIPLE MENU TREES

## CONFIG

**CONFIG: MANUAL AUTO[OFF ]**  
**OPTIONS REMOTE-CONTROL**

The sub-branches available are:

**MANUAL** This menu sub-branch permits the user to select which traffic modem the switch should bridge or backup.

**AUTO[ON]** This menu sub-branch permits the user to turn auto mode off or on. The currently selected state is always shown on this menu.

**OPTIONS** This menu sub-branch permits the user to set several operating parameters of the switch that pertain to enabling or disabling the availability of traffic modems, the reporting of faults and time delays for responding to faults.

**REMOTE** This menu sub-branch permits the user to define whether the switch is being controlled locally, or remotely.

**IMPORTANT NOTE:** The switch may be monitored over the remote control bus at any time. When in Local mode, however, configuration parameters may only be changed through the front panel. Conversely, when in Remote mode, the unit may be monitored from the front panel, but configuration parameters via may only be changed remote control bus.

(CONFIG) MANUAL

**MANUAL SELECT :**  
**BRIDGE : 02      BACKUP : 02**

The user is prompted to enter which traffic modem the switch should either bridge or backup. Both these selections are available when the switch is in Manual mode (Auto is OFF), and using the **UP/DOWN** keys will scroll through all active traffic modems, skipping those that are inactive. When in Auto mode, the switch controls backing up any active traffic modem, based on its fault relay activity. Therefore, the BACKUP selection is unavailable, and the BRIDGE selection is also locked out when the switch is currently backing up a traffic modem since the redundant modem is busy.

(CONFIG) AUTO[OFF or ON]



**OPERATING MODE:  
 AUTO-OFF AUTO-ON (ENTER)**

The user is prompted to turn Auto mode OFF or ON. When OFF (Manual mode), the switch does not respond automatically to any modem faults and simply performs whatever manual setting the user performs on the previous menu. The STORED EVENT indicator blinks when in Manual mode to alert the user that the switch is effectively not in use.

(CONFIG) OPTIONS

**OPTIONS: ACTIVE MODEMS  
 HOLDOFFS ALARM MASK**

The user is prompted to select various options concerning which modems connected to the switch are active (available for bridging or backing up) and how the switch will react to various faults.

(CONFIG, OPTS) ACTIVE MODEMS

**ACTIVE MODEMS: (ENTER)  
 1 2 3 - 5 6 - 8 9 10**

The user is prompted to select which traffic modems should be available for bridging and backing up. A '-' will appear in place of the modem number if it is de-selected. If a traffic modem interface is not plugged into any slot, that position will not be allowed to be activated. If the switch is unable to read the configuration of the modem in a particular position, that modem is also not allowed to be activated. A modem must be active in order for it to be manually or automatically bridged or backed up.

(CONFIG, OPTS) HOLDOFFS

**BACKUP HOLDOFF SEC: 05  
 RESTORE HOLDOFF SEC: 10**

The user is prompted to set the holdoffs, or delay times between the switch's modem alarm detection and its reaction to the event. These holdoffs are only applicable when the switch is in Auto mode. When an active modem exhibits an unmasked fault, the switch bridges it with the redundant and checks that the

latter is not also faulted. If there is no fault, the *backup holdoff* determines how long the switch will wait before performing the actual backup, or switchover of traffic to the redundant modem.

When the switch is currently backing up a traffic modem, and that offline modem's fault clears, the switch will continue to back it up unless another active modem becomes faulted. In this case, the *restore holdoff* is the length of time that the originally faulted modem must stay unfaulted before the switch will automatically put it back online so that the redundant modem is available to bridge the newly faulted modem. Both holdoffs can be set from 2 to 99 seconds.

(CONFIG, OPTS) ALARM MASK

```
ALARM MASK: MODEM-ALARMS
SW-ALARMS  AUDIO (ENTER)
```

The switch logs and reacts to both modem faults and its own faults. Types of either may be masked using this sub-menu. In addition, an audible buzzer can be enabled as an additional indicator.

(CONFIG, OPTS, MASK) MODEM ALARMS

```
MODEM ALARM MASK: NONE
TX  RX  TX+RX  (ENTER)
```

The user is prompted to mask Transmit or Receive Traffic faults (or both) from being reacted to by the switch. This not only prevents the switch from performing Auto mode functions when these modem faults are sensed, but also keeps the faults from being logged by the switch. Note that these selections are global to all the modems. If masking of individual modem faults is desired, it should be done directly on the modem. Unmasked modem faults are logged on both active and inactive modems.

(CONFIG, OPTS, MASK) SWITCH ALARMS

```
SWITCH ALARM MASK:  NONE
✓PSU-A PSU-B\      (ENTER)
```

The user is prompted to select which, if either, of the plug-in power supply units should be ignored in case any of their voltage outputs are monitored by the switch as being out of range. Only one of the units can be masked at a time. Normally this would be done if the user wishes to run with only one supply, or if a bad supply had been removed for service or replacement.

(CONFIG, OPTS, MASK) AUDIO

```
AUDIO MASK: NONE SW-ALMS
MODEM ALMS BOTH (ENTER)
```

For all switch or modem alarms that are unmasked, the user may select which alarm types should force the switch to react with an audible buzzer located behind the front panel. In addition, a relay closure to ground activates on pin 20 of the System Alarms connector so that the user may attach other indicators.

(CONFIG) REMOTE CONTROL

```
SELECT REMOTE CONTROL:
LOCAL REMOTE (PRESS ENT)
```

The user is prompted to select LOCAL or REMOTE using the *LEFT/RIGHT* arrow keys, then to press *ENTER*.

(CONFIG, REM-CNTL) If LOCAL is selected then remote control will be disabled. Remote monitoring is still possible.

(CONFIG, REM-CNTL) If REMOTE is selected then the following sub-menus will be displayed:

```
REMOTE CONTROL: BAUDRATE
INTERFACE (PRESS ENTER)
```

The user is prompted to select BAUDRATE or INTERFACE, using the *LEFT/RIGHT* arrow keys, then to press *ENTER*.

(CONFIG, REM, BAUD) If BAUD RATE is selected:

```
EDIT LOCAL BUS BAUDRATE:  
19200 BAUD (PRESS ENTER)
```

The user is prompted to edit the baud rate of the remote control bus, connected locally to the M&C computer. The value is changed using the **UP/DOWN** arrow keys. The user should then press **ENTER**. Values of 300, 1200, 2400, 4800, 9600 and 19200 baud are possible. Note that the asynchronous character format is **FIXED** at 8 data bits, 1 stop bit, no parity (8-1-N).

(CONFIG, REM, INTFC) If INTERFACE is selected:

```
ELECT. INTERFACE: RS232  
RS485-2W RS485-4W (ENT)
```

The user is prompted to select RS232, RS485 (2-wire), or RS485 (4-wire), using the **LEFT/RIGHT** arrow keys, then to press **ENTER**. At this point the user will be further prompted to enter the bus address. In RS232 mode the bus address is fixed at 0, and the following screen will be displayed:

(CONFIG, REM, INTFC, ADDR) RS232 BUS ADDRESS

```
IN RS232 MODE THE BUS  
ADDRESS IS FIXED AT 0000
```

However, if either RS485 mode is selected, the user will be further prompted:

(CONFIG, REM, INTFC, ADDR) RS485 BUS ADDRESS:

```
EDIT SWITCH BUS ADDRESS:  
3000 (PRESS ENTER)
```

The user is prompted to edit the RS485 bus address of this unit. This is accomplished by selecting the digit to be edited, using the **LEFT/RIGHT** arrow keys. The value of the digit is then changed using the **UP/DOWN** arrow keys. The user should then press **ENTER**. The valid addresses are 1000, 3000, 5000 and 7000 only, as explained in the Remote section of this manual.

INFO (Information)

```
INFO:    SWITCH-ID  SETUP
IF-SWITCH  REMCONT  MASK
```

The user is prompted to select SWITCH-ID, SETUP, IF-SWITCH, REMCONT or MASK using the *LEFT/RIGHT* keys, then *ENTER*. These screens display information on the current configuration of the switch without risking inadvertent alterations.

(INFO) SWITCH-ID

```
SWITCH ID:
THIS IS A TEST MESSAGE
```

This displays the user-defined Switch ID string, which is entered via the UTILITY, SWITCH-ID screen. To return to the previous menu, press *ENTER* or *CLEAR*.

(INFO) SETUP

```
TM: 1 2 3 4 5 - 7 - 9 10
AUTO:OFF BKUP:05 REST:20
```

The information on this screen reflects some of the settings configured in the CONFIG, OPTIONS menu. Active traffic modems are listed on the top line, with Auto mode and the two holdoff times listed on the bottom.

(INFO) IF-SWITCH

```
TRANSPONDER SWITCH IS
ABSENT
```

This screen shows whether a CRS-280 IF Transponder Switch is connected to the CRS-200 1:N Redundancy Switch. When an IF switch is present, the second line will indicate "PRESENT", and any offline modem (TM or RM) will not have its Transmit IF muted by the CRS-200.

(INFO) REMCONT (Remote Control Info)

```
REM CNTL: ON  RS485-4W
ADDRESS: 5000 19200 BAUD
```

This screen shows if the unit is in LOCAL or REMOTE mode, and gives details of the electrical interface type selected, the unit's address, and the baud rate selected. Pressing *ENTER* takes the user back to the previous menu.

(INFO) MASK (Alarm Mask Info)

```
ALARMS MASKED: MODEM-TX
MODEM-RX  ✓PSU-A PSU-B\
```

This screen shows which alarms are currently masked. If an alarm is not masked, a blank is displayed in the relevant screen position. Power Supplies A and B cannot be masked at the same time, but are shown together here to indicate their relative positions.

MONITOR

```
MONITOR: STATUS SW-ALARM
STORED-EVENTS TM-CONFIGS
```

The user is prompted to select STATUS, SW-ALARM, STORED EVENTS, or TM-CONFIGS using the *LEFT/RIGHT* arrow keys, then to press *ENTER*.

(MONITOR) STATUS

```
TM 02 IS BRIDGED BY RM
BACKUP HOLDOFF: 05 SEC
```

This screen shows the current status of the switch. When the redundant modem is not backing up any of the traffic modems, the display will show which TM is currently being bridged by the RM. If Auto mode is on, it will also show the backup holdoff should the bridged TM fail. If Auto mode is off, the second line displays "OFF". When the switch has taken the bridged TM offline and replaced it with the RM (whether done manually or automatically), the screen changes as shown below:

```
TM 02 IS BACKED UP BY RM
RESTORE HOLDOFF: OFF
```

Now, the restore holdoff will be shown on the second line if Auto mode is on.

(MONITOR) STORED EVENTS

```
STORED EVENTS:      VIEW
CLEAR ALL  (PRESS ENTER)
```

The user is prompted to select VIEW or CLEAR ALL, using the *LEFT/RIGHT* arrow keys, then to press *ENTER*.

(MON, EVENTS) VIEW

```
LOG23: 26/01/00 10:37:32
FT-06 RX ALARM (UP/DN)
```

The user may scroll backwards or forwards through the entries in the event log, using the **UP/DOWN** arrow keys. Pressing **ENTER** or **CLEAR** will take the user back to the previous menu. The event log can store up to 98 events. When a fault condition occurs, it is time-stamped and put into the log. Next to the FT (for fault) indicator is either the TM number, RM (redundant modem fault) or SW (switch fault). Similarly, when the fault condition clears, this is also recorded, as shown below:

```
LOG23: 26/01/00 10:37:35
OK-06 RX ALARM (UP/DN)
```

If the user selects CLEAR ALL, the event log is cleared, and the user is taken directly back to the previous menu. However, if there are faults present on the unit at this time, they will be re-time-stamped, and new log entries will be generated. Note that in accordance with international convention, the date is shown in DAY-MONTH-YEAR format.

(MON) TM-CONFIGS (Traffic Modem Configurations)

```
VALID CONFIGS SAVED FOR:
TM# 1 2 3 4 5 6 7 8 - 10
```

This screen monitors the traffic modem configurations saved in the switch's non-volatile memory, that are sent to the RM whenever it is told to bridge a new TM. A '-' indicates that no valid configuration has been saved for that TM position. This is usually due to a remote communication problem between that modem and the switch, and will automatically keep that TM from being activated on the CONFIG, OPTIONS menu.

STORE/LD (Store or Load Configuration)

```
STORE/LOAD CONFIG:
STORE LOAD (PRESS ENTER)
```

The user is prompted to select STORE or LOAD using the **LEFT/RIGHT** arrow keys, then to press **ENTER**. These sub-menus permit the user to store or load up to 10 different switch configurations in its non-volatile memory. These are configurations for the switch itself, not the modems attached to it.

(STO/LD) STORE

**STORE CONFIGURATION TO  
LOCATION: 10 (ENTER)**

The user is prompted to select the location to store the current configuration to, using the **UP/DOWN** arrow keys, then to press **ENTER**. Locations 1 through 10 are available. If the selected location does not contain a previously stored configuration, the following screen is displayed:

**YOUR CONFIGURATION HAS  
BEEN STORED! (ENTER)**

Pressing **ENTER** or **CLEAR** will take the user back to the previous menu. If, however, the selected location contains a previously stored configuration, the following screen is displayed:

**WARNING! LOC 10 CONTAINS  
DATA OVERWRITE? NO YES**

The user is prompted to select NO or YES using the **LEFT/RIGHT** arrow keys, then to press **ENTER**. Selecting YES will overwrite the existing configuration at the selected location.

(STO/LD) LOAD

**LOAD CONFIGURATION FROM  
LOCATION: 10 (ENTER)**

The user is prompted to select the location to load a configuration from, using the **UP/DOWN** arrow keys, then to press **ENTER**. Locations 1 through 10 are available. If the selected location contains valid data, the following screen will be displayed:

**THE NEW CONFIGURATION  
HAS BEEN LOADED (ENTER)**

Pressing **ENTER** or **CLEAR** will take the user back to the previous menu. If, however, the selected location does not contain valid data, the following screen will be displayed:

**WARNING! LOC 10 CONTAINS  
NO DATA! (ENTER)**

Pressing **ENTER** or **CLEAR** will take the user back to the previous menu.



## UTIL (Utility)

```
UTILITY: SET-RTC DISPLAY
SWITCH-ID (PRESS ENTER)
```

The user is prompted to select SET-RTC, DISPLAY, or SWITCH-ID, using the *LEFT/RIGHT* arrow keys, then to press *ENTER*. This sub-menu permits the user to select from a number of different utility functions, which are described below:

## (UTILITY) SET-RTC (Set Real-Time Clock)

```
EDIT REAL TIME CLOCK:
12:00:00 24/04/00 (ENT)
```

The user is prompted to edit the time and date settings of the real-time clock. This is accomplished by selecting the digit to be edited, using the *LEFT/RIGHT* arrow keys. The value of the digit is then changed using the *UP/DOWN* arrow keys. Note that in accordance with international convention, the date is shown in DAY-MONTH-YEAR format. The user should then press *ENTER*.

## (UTILITY) DISPLAY (Display Brightness)

```
EDIT DISPLAY BRIGHTNESS:
100% (PRESS ENTER)
```

The user is prompted to edit the display brightness, using the *UP/DOWN* arrow keys. The user should then press *ENTER*.

## (UTILITY) SWITCH-ID

```
EDIT SWITCH ID: (ENTER)
---- THIS IS A TEST ----
```

The user is prompted to edit the Switch ID string, using the *LEFT/RIGHT* and *UP/DOWN* arrow keys. Only the bottom line is available (24 characters). The cursor selects the position on the bottom line (*LEFT/RIGHT*) and the character is then edited (*UP/DOWN*). The following characters are available:

Space ( ) \* + - , . / 0-9 and A-Z.

When the user has composed the string, press *ENTER*.

## 10 FLASH UPGRADING

From time to time it may be necessary to update the internal firmware of the switch, either to correct any problems that may be reported in operational use, or to add new features. In the past, this has been accomplished by using EPROMs, which had to be physically shipped to the user. The user would then have to remove the lid from the unit, locate and remove the old EPROM, and replace it with an updated EPROM.

The CRS-200 uses 'flash memory' technology internally, and new firmware can be uploaded to the unit from an external PC. This makes software upgrading very simple, and updates can now be sent via the Internet, E-mail, or on floppy disk. The upgrade can be performed without opening the unit, by simply connecting the switch to the serial port of a computer.

The cable to connect the PC to the switch is the same as is used for normal RS232 remote control, and comprises 3-wires between 9 pin 'D' type female connectors. This is shown in the Cables Section.

Comtech will distribute a free software utility, that is designed to run under Windows 3.1x, Windows 95/98 or Windows NT. This utility program is called CCCFlash.exe, and should be copied to the user's computer hard disk. This is the same program that is used to flash upgrade the CDM-550T modem and other Comtech products. Along with this, the user will receive the latest firmware file (for example, 200V102.ccc), that the user should copy to the same sub-directory (folder).

The user then connects the switch remote control port to an unused serial port on the user's computer, and executes the program. The user should follow the instructions presented on the screen, and the upload will take place automatically. Following the successful upload process, the unit will automatically re-start, running the new version of firmware. During this process, the non-volatile RAM, storing the configuration of the switch, will be erased, so the user is then required to re-enter the desired configuration parameters.

Full on-line help is provided with CCCFlash.exe, but if users experience a problem, or have a question, they should contact Comtech Technical Support.

## 11 SUMMARY OF SPECIFICATIONS

Type	1:N protection system, N=10 maximum, bridging architecture, C161 control processor
Operating Modes	Automatic switch to redundant modem (RM) based on modem alarms Manual switch to RM Manual parallel (bridging) of RM to any one of N traffic modems (TM) Remove selected TMs from switch control Programmable holdoff times for automatic switching (2-99 seconds)
Redundant Modem Signal Source	Any one of N traffic paths, both Transmit terrestrial data and Receive IF (Parallel operation, or bridging)
IF Switching	Passive splitting and combining using carrier muting of offline modem in a single up/downconverter system. Operation with CRS-280 Transponder Switch required for multiple up/downconverter system.
Switching Time	Manual = 1 second if bridging selected TM, 6 seconds if not Auto = 2 second if bridging selected TM, 7 seconds if not
Modem Interface	25-pin 'D' type male, requiring male-female pin-to-pin cable with all 25 pins connected. All traffic, modem alarms and remote link with switch are included on this interface.
Terrestrial Data Interfaces	RS-422/EIA-530, V.35 or RS-232 synchronous DCE RS-232 asynchronous DCE X.21 synchronous DCE or DTE <b>(NOTE: Modem interface types connected to one switch may be mixed)</b>
Front Panel	Vacuum Fluorescent Display (2 lines, 24 characters each) Tactile Keypad (6 keys) Switch Status LEDs (Unit Fault, Remote ON/OFF, Stored Events) Modem Status LEDs (Unit, Tx & Rx Faults, Bridged Status, Online)
Audible Alarm	2 tone buzzer, programmable to react to modem or switch faults
Power Supply	2 independent supplies 100-250 volts AC (+/- 10%) Fused IEC connectors, 25 watts max total

Dimensions and Weight	4U chassis x 275 mm deep, 18 lbs (8.2 kgs)
Compatible Modems	CDM-500 (2.4 to 512 kbps, B/QPSK, Viterbi) CDM-550 (2.4 to 2048 kbps, B/Q/OQPSK, Viterbi/Sequential w/RS) CDM-550T (added Turbo Codec, AUPC and uncoded operation)
Environmental	0 to 50 °C
EMC and safety	EN 55022 Class B (Emissions) EN 50082-1 (Immunity) EN 60950 (Safety)
FCC approvals	FCC Part 15 Class B

## 12 REMOTE CONTROL

### 12.1 INTRODUCTION

This section describes the protocol and message command set for remote monitor and control of the CRS-200 Redundancy Switch.

The electrical interface is either an RS485 multi-drop bus (for the control of many devices) or an RS232 connection (for the control of a single device), and data is transmitted in asynchronous serial form, using ASCII characters. Control and status information is transmitted in packets, of variable length, in accordance with the structure and protocol defined in later sections.

### 12.2 RS485

For applications where multiple devices are to be monitored and controlled, a full-duplex (or 4-wire plus ground) RS485 is preferred. Half-duplex (2-wire plus ground) RS485 is possible, but is not preferred.

In full-duplex RS485 communication there are two separate, isolated, independent, differential-mode twisted pairs, each handling serial data in different directions. It is assumed that there is a 'controller' device (a PC or dumb terminal), that transmits data, in a broadcast mode, via one of the pairs. Many 'target' devices are connected to this pair, that all simultaneously receive data from the controller. The controller is the **only** device with a line-driver connected to this pair - the target devices only have line-receivers connected.

In the other direction, on the other pair, each target has a tri-stateable line driver connected, and the controller has a line-receiver connected. All the line drivers are held in high-impedance mode until one (and only one) target transmits back to the controller.

Each target has a unique address, and each time the controller transmits, in a framed 'packet' of data, the address of the intended recipient target is included. All of the targets receive the packet, but only one (the intended) will reply. The target enables its output line driver, and transmits its return data packet back to the controller, in the other direction, on the physically separate pair.

RS 485 (full duplex) summary:

- \* Two differential pairs - one pair for controller to target, one pair for target to controller.
- \* Controller-to-target pair has one line driver (controller), and all targets have line-receivers.
- \* Target-to-controller pair has one line receiver (controller), and all targets have tri-state drivers.

### 12.3 RS232

This is a much simpler configuration in which the controller device is connected directly to the target via a two-wire-plus-ground connection. Controller-to-target data is carried, via RS232 electrical levels, on one conductor, and target-to-controller data is carried in the other direction on the other conductor.

### 12.4 BASIC PROTOCOL

Whether in RS232 or RS485 mode, all data is transmitted as asynchronous serial characters, suitable for transmission and reception by a UART. In this case, the asynchronous character format is fixed at 8 data bits, one stop bit, no parity. The baud rate may vary between 300 baud and 19,200 baud.

All data is transmitted in framed packets. The controller is assumed to be a PC or ASCII dumb terminal, that is in charge of the process of monitor and control. The controller is the only device that is permitted to initiate, at will, the transmission of data. Targets are only permitted to transmit when they have been specifically instructed to do so by the controller.

All bytes within a packet are printable ASCII characters, less than ASCII code 127. In this context, the Carriage Return and Line Feed characters are considered printable.

**All messages from controller to target require a response (with one exception).** This will be either to return data that has been requested by the controller, or to acknowledge reception of an instruction to change the configuration of the target. **The exception to this is when the controller broadcasts a message (such as Set time/date) using Address 0, when the target is set to RS485 mode.**

### 12.5 PACKET STRUCTURE

Controller-to-target:

Start of Packet	Target Address	Address De-limiter	Instruction Code	Code Qualifier	Optional Arguments	End of Packet
< ASCII code 60 (1 character)	(4 characters)	/ ASCII code 47 (1 character)	(3 characters)	= or ? ASCII code 61 or 63 (1 character)	(n characters)	Carriage Return ASCII code 13 (1 character)

Example: <0000/RSH=30{CR}

Target-to-controller:

Start of Packet	Target Address	Address De-limiter	Instruction Code	Code Qualifier	Optional Arguments	End of Packet
> ASCII code 62 (1 character)	(4 characters)	/ ASCII code 47 (1 character)	(3 characters)	=, ?, !, or * ASCII code 61, 63, 33 or 42 (1 character)	(From 0 to n characters)	Carriage Return, Line Feed ASCII code 3,10 (2 characters)

Example: >0000/BBU=107{CR}{LF}

Each of the components of the packet is now explained.

#### START OF PACKET

**Controller to Target:** This is the character '<' (ASCII code 61)

**Target to Controller:** This is the character '>' (ASCII code 62)

Because this is used to provide a reliable indication of the start of packet, these two characters may not appear anywhere else within the body of the message.

#### ADDRESS

While up to 9,999 devices can be uniquely addressed, **connection to the 1:N Redundancy Switch imposes some basic limitations**. In RS232 applications the switch's "base address" must be fixed at 0000. The 11 modems that may be connected to it can be accessed via the switch at addresses 0100 (for Traffic Modem #1), 0200 (for TM #2) and on up to 1000 (for TM #10) and 1100 (for the Redundant Modem). Valid remote commands and queries which can be sent to the modems via the switch depend upon the modem model number used. Please consult the manual for the modem being used. There are similar restrictions on address selection for distant-end units (being accessed by EDMAC) and Comtech transceivers, connected either locally or at the distant-end of a link. Please consult the **SatMac** help file for more details.

#### **IMPORTANT NOTE:**

**Comtech's SatMac software (Version 2.3 or higher) is configured to monitor and control a CRS-200 Redundancy system.**

For ease of configuration, the SatMac software auto-configures the addresses of all devices (Modems and Transceivers) defined within a system. The **SatMac** help file contains more details of address restrictions

In RS485 applications, the same indexing of the modems based on the switch's address still applies. Now, however, the switch itself may be set to 1000, 3000, 5000 or 7000. This allows up to 4 switches to be connected on the same bus. For example, if the base address of the switch is set to 5000, the address of TM #3 is 5300. Note that in either RS232 or RS485 mode the internal link from the switch to all the modems connected to it **is fixed at RS232**. This means that the modem addresses (0100-1100) do **not** have to be set on each modem. Since they are in RS232 mode, **their addresses stay at 0000**. Commands are routed by the switch to the appropriate modem based on the position of its TM Interface.

*Important note:* The controller sends a packet with the address of a target - the *destination* of the packet. When the target responds, the address used is the *same* address, to indicate to the controller the *source* of the packet. The controller does not have its own address.

#### INSTRUCTION CODE

This is a three-character alphabetic sequence that identifies the subject of the message. Wherever possible, the instruction codes have been chosen to have some significance. For example, TFQ is for transmit frequency, BKH is for backup holdoff, etc. This aids in the readability of the message if seen in its raw ASCII form. Only upper case alphabetic characters may be used (A-Z, ASCII codes 65 - 90).

#### INSTRUCTION CODE QUALIFIER

This is a single character that further qualifies the preceding instruction code.

Code Qualifiers obey the following rules:

- 1) From Controller to Target, the only permitted values are:
  - = (ASCII code 61)
  - ? (ASCII code 63)

They have these meanings:

The '=' code (controller to target) is used as the assignment operator, and is used to indicate that the parameter defined by the preceding byte should be set to the value of the argument(s) that follow it. For example, in a message from controller to target, TFQ=070.0000 would mean 'set the transmit frequency to 70 MHz'

The '?' code (controller to target) is used as the query operator, and is used to indicate that the target should return the current value of the parameter defined by the preceding byte. For example, in a message from controller to target, TFQ? would mean 'return the current value of the transmit frequency'



- 2) From Target to Controller, the only permitted values are:
- = (ASCII code 61)
  - ? (ASCII code 63)
  - ! (ASCII code 33)
  - \* (ASCII code 42)

They have these meanings:

The '=' code (target to controller) is used in two ways:

First, if the controller has sent a query code to a target (for example TFO?, meaning 'what's the Transmit frequency?'), the target would respond with TFO=xxx.xxxx, where xxx.xxxx represents the frequency in question.

Second, if the controller sends an instruction to set a parameter to a particular value, then, providing the value sent in the argument is valid, the target will acknowledge the message by replying with TFO= (with no message arguments).

The ? code (target to controller) is only used as follows:

If the controller sends an instruction to set a parameter to a particular value, then, if the value sent in the argument is **not** valid, the target will acknowledge the message by replying (for example) with TFO? (with no message arguments). This indicates that there was an error in the message sent by the controller.

The \* code (target to controller) is only used as follows:

If the controller sends an instruction to set a parameter to a particular value, then, if the value sent in the argument **is** valid, BUT the modem will not permit that particular parameter to be changed at that time, the target will acknowledge the message by replying (for example) with TFO\* (with no message arguments).

The ! code (target to controller) is only used as follows:

If the controller sends an instruction code that the target does not recognize, the target will acknowledge the message by echoing the invalid instruction, followed by the ! character with. Example: XYZ!

#### MESSAGE ARGUMENTS

Arguments are not required for all messages. Arguments are ASCII codes for the characters 0 to 9 (ASCII 48 to 57), A to Z (ASCII 65 to 90), period (ASCII 46) and comma (ASCII 44).

#### END OF PACKET

Controller to Target: This is the 'Carriage Return' character (ASCII code 13)

Target to Controller: This is the two-character sequence 'Carriage Return', 'Line Feed'. (ASCII code 13, and code 10).

Both indicate the valid termination of a packet.

Parameter Type	Command (Instruction Code and qualifier)	Arguments for Command or Response to Query	Description of arguments (note that all arguments are ASCII numeric codes, that is, ASCII codes between 48 and 57)	Response to Command (target to controller)	Query (Instruction Code and qualifier)	Response to query (target to controller)
Set RTC Date	DAY=	6 bytes, numerical	Command or query A command in the form ddmmyy, where; dd = day of the month, between 01 and 31, mm = month of the year, between 01 and 12 and yy = year, between 97 and 96 (1997 to 2000, then 2000 to 2096) Example: DAY=240457 would be April 24, 2057	DAY= (message ok) DAY? (received ok, but invalid arguments) DAY* (message ok, but not permitted in current mode)	DAY?	DAY=xxxxxx (same format as command arguments)
Set RTC Time	TIM=	6 bytes, numerical	Command or query A command in the form hhmmss, indicating the time from midnight, where hh = hours, between 00 and 23; mm = minutes, between 00 and 59, and ss = seconds, between 00 and 59 Example: TIM=231259 would be 23 hours, 12 minutes and 59 seconds from midnight.	TIM= (message ok) TIM? (received ok, but invalid arguments) TIM* (message ok, but not permitted in current mode)	TIM?	TIM=xxxxxx (same format as command arguments)
Operating Mode	OPM=	1 byte, numerical	Command or Query. Sets the operating mode: 0 = manual mode 1 = auto mode	OPM= (message ok) OPM? (received ok, but invalid arguments) OPM* (message ok, but not permitted in current mode)	OPM?	OPM=x (same format as command arguments)
Bridged or Backup Modem Number	BBU=	3 bytes, numerical	Command or Query. Sets or queries the bridged/backup state with the 1 <sup>st</sup> byte, followed by the selected TM to be acted on: 1 <sup>st</sup> byte: 0= bridged, 1= backup (this can only be set to 1 when in manual mode) last 2 bytes: 01-10 for selected TM	BBU= (message ok) BBU? (received ok, but invalid arguments) BBU* (message ok, but not permitted in current mode)	BBU?	BBU=xxx (same format as command arguments)

Parameter Type	Command (Instruction Code and qualifier)	Arguments for Command or Response to Query	Description of arguments (note that all arguments are ASCII numeric codes, that is, ASCII codes between 48 and 57)	Response to Command (target to controller)	Query (Instruction Code and qualifier)	Response to query (target to controller)
Active Modems	ACT=	10 bytes, numerical	Command or Query. Sets or queries the <b>desired</b> state of all 10 traffic modems: 0 = de-activate traffic modem 1 = activate traffic modem	ACT= (message ok) ACT? (received ok, but invalid arguments) ACT* (message ok, but not permitted in current mode)	ACT?	ACT=xxxxxxx xx (same format as command arguments)
Active Modem Query	N/A	10 bytes, numerical	Query only Returns the state of all 10 traffic modems, which is usually that set by ACT, but possibly overruled by current conditions:  0 = TMI not present (cannot be activated) 1 = TMI present but switch unable to get a configuration for that modem due to remote comm or other error (also cannot be activated) 2 = TMI present and modem available, but currently inactive 3 = TMI present and modem available, and currently active	N/A	AMQ?	AMQ=xxxxxxx xx (same format as command arguments)
Backup Holdoff Time	BKH=	2 bytes, numerical	Command or Query. Sets or queries the backup holdoff delay time used when auto mode prepares to backup a faulted modem: 02-99 = # of seconds delay after redundant modem has acquired traffic modem's configuration before online swap actually takes place	BKH= (message ok) BKH? (received ok, but invalid arguments) BKH* (message ok, but not permitted in current mode)	BKH?	BKH=xx (same format as command arguments)

Parameter Type	Command (Instruction Code and qualifier)	Arguments for Command or Response to Query	Description of arguments (note that all arguments are ASCII numeric codes, that is, ASCII codes between 48 and 57)	Response to Command (target to controller)	Query (Instruction Code and qualifier)	Response to query (target to controller)
Restore Holdoff Time	RSH=	2 bytes, numerical	Command or Query. Sets or queries the restore holdoff delay time used when auto mode prepares to return a previously faulted modem back online due to another traffic modem's failure: 02-99 = # of seconds after offline traffic modem lost its fault before it is put back online so that redundant modem can bridge the newly faulted modem	RSH= (message ok) RSH? (received ok, but invalid arguments found) RSH * (message ok, but not permitted in current mode)	RSH?	RSH =xx (same format as command arguments)
Modem Alarm Mask	MAM=	1 byte, numerical	Command or Query. Sets or queries the modem alarm mask: 0 = no faults masked 1 = Tx faults masked 2 = Rx faults masked 3 = Both Tx and Rx faults masked	MAM = (message ok) MAM? (received ok, but invalid arguments found) MAM * (message ok, but not permitted in current mode)	MAM?	MAM =x (same format as command arguments)
Switch Alarm Mask	SAM=	1 byte, numerical	Command or Query. Sets or queries the modem alarm mask: 0 = no faults masked 1 = PSU A faults masked 2 = PSU A faults masked	SAM = (message ok) SAM? (received ok, but invalid arguments found) SAM * (message ok, but not permitted in current mode)	SAM?	SAM =x (same format as command arguments)
Audio Alarm Mask	AAM=	1 byte, numerical	Command or Query. Sets or queries the audio alarm mask: 0 = no faults masked (audio enabled in response to any fault) 1 = Switch faults masked 2 = Modem faults masked 3 = All faults masked (audio never enabled)	AAM = (message ok) AAM? (received ok, but invalid arguments found) AAM * (message ok, but not permitted in current mode)	AAM?	AAM =x (same format as command arguments)
Switch ID string	SID=	24 bytes, ASCII	Command or Query. Sets or queries the user-defined Switch ID string, which is a fixed length of 24 characters. Valid characters include: Space ( ) * + - , . / 0-9 and A-Z.	SID= (message ok) SID? (received ok, but invalid arguments found)	SID?	SID=xxxxxxx xxxxxxxxxxxx xx (same format as command arguments)

Parameter Type	Command (Instruction Code and qualifier)	Arguments for Command or Response to Query	Description of arguments (note that all arguments are ASCII numeric codes, that is, ASCII codes between 48 and 57)	Response to Command (target to controller)	Query (Instruction Code and qualifier)	Response to query (target to controller)
Switch Global Configuration	SGC=	21 bytes, numerical	Command or Query. Global configuration of switch, in the form: OaaaaaaaaaBNNbrrrMSAsssssss where: O = Operating Mode - same as OPM= (1 bytes) a = Active Modems - same as ACT= (10 bytes) B = Bridge/Backup State – same as 1 <sup>st</sup> half of BBU= (1 byte) N = Selected TM Number - same as 2 <sup>nd</sup> half of BBU= (2 byte) b = Backup Holdoff Time – same as BKH= (2 byte) r = Restore Holdoff Time – same as RSH= (2 byte) M = Modem Alarm Mask – same as MAM= (1 byte) S = Switch Alarm Mask – same as SAM= (1 byte) A = Audio Alarm Mask - same as AAM= (1 bytes) s = 8 spare bytes	SGC= (message ok) SGC? (received ok, but invalid arguments found)	SGC?	SGC=Oaaaaaaaa aaaBNNbrrrMS Asssssss (same format as command arguments)
Config Store	CST=	1 byte, numerical, 0 to 9	Forces the unit to store the current modem configuration in Configuration Memory location defined by the one byte argument (0 to 9). Example CST=4 (Store current config in location 4) WARNING: Use with caution! If the location already contains data it will be automatically overwritten. If in doubt, query the location first.	CST= (message ok) CST? (received ok, but invalid arguments found)	CST?n, where n is 0 to 9	Return the same format as the MGC with The form: CST= for a valid config, and CST* where no valid config is found
Config Load	CLD=	1 byte, numerical, 0 to 9	Command only. Forces the switch to retrieve the Configuration Memory location defined by the one byte argument (0 to 9). and to re-program the switch with that stored configuration.	CLD= (message ok) CLD? (received ok, but invalid arguments found) CST* (message ok, but the requested location does not contain a valid configuration)	N/A	N/A
Clear All Stored Events	CAE=	None	Command only Instructs the unit to clear all Stored Events This command takes no arguments.	CAE= (message ok)	N/A	N/A

Parameter Type	Command (Instruction Code and qualifier)	Arguments for Command or Response to Query	Description of arguments (note that all arguments are ASCII numeric codes, that is, ASCII codes between 48 and 57)	Response to Command (target to controller)	Query (Instruction Code and qualifier)	Response to query (target to controller)
Retrieve next 5 unread Stored Events	N/A	75 bytes	<p>Query only</p> <p>Switch returns the oldest 5 Stored Events which have not yet been read over the remote control. Reply format: {CR}Sub-body{CR}Sub-body{CR}Sub-body{CR}Sub-body{CR}Sub-body, where Sub-body = ABCddmmyyhhmss:</p> <p>A being the fault/clear indicator, where: F = Fault, C = Clear, I = Info</p> <p>B being the fault type, where: C = Switch Fault/Clear, 1,2,...A,B = Modem Fault/Clear (B = RM) D = Power on/off, or log cleared (Info events)</p> <p>C being the fault code, where the value depends on fault type: Switch codes are 1 to D, defined the same as FLT string. Modem codes are 1= Unit, 2= Rx traffic, 3= Tx traffic Info codes are: 0= Power off, 1= Power on, 2= Log cleared.</p> <p>If there are no new events, the unit replies with RNE? If fewer than 5 events remain, the last positions are zero</p>	N/A	RNE?	RNE={CR}ABCddmmyyhhmss{CR}ABCddmmyyhhmss{CR}ABCddmmyyhhmss{CR}ABCddmmyyhhmss{CR}ABCddmmyyhhmss{CR}ABCddmmyyhhmss (see description for details of arguments)
Retrieve Number of unread Stored Events	N/A	2 bytes, numerical	<p>Query only.</p> <p>Switch returns the number of Stored Events which remain unread, in the form xx. Note: This means unread over the remote control – viewing the stored events from the front panel of the modem does not affect this value. Example reply: NUE=98</p>	N/A	NUE?	NUE=xx (see description for details of arguments)
Local/Remote Status	LRS=	1 byte, value of 0 or 1	<p>Command or query</p> <p>Sets or queries the local/remote status of the switch: 0 = local 1 = remote</p>	LRS= (message ok) LRS? (received ok, but invalid arguments found)	LRS?	LRS=x (see description for details of arguments)

Parameter Type	Command (Instruction Code and qualifier)	Arguments for Command or Response to Query	Description of arguments (note that all arguments are ASCII numeric codes, that is, ASCII codes between 48 and 57)	Response to Command (target to controller)	Query (Instruction Code and qualifier)	Response to query (target to controller)
Serial Number	SNO=	4 bytes numerical 0000 to 9999	Command portion is FACTORY USE ONLY. Used to set or Query the units 4 digit serial number. Unit returns its S/N, in the form xxxx. Example: SNO=1765	SNO= (message ok) SNO * (message ok, but not permitted in current mode)	SNO?	SNO=xxxx (see description for details of arguments)
Software Revision	N/A	4 bytes, numerical	Query only. Unit returns the value of internal software revision installed in the unit, in the form x.xx Example: SWR=1.03 (Ver 1.03)	N/A	SWR?	SWR=x.xx (see description for details of arguments)
Equipment ID	N/A	4 bytes, numerical	Query only. Switch returns information concerning the equipment identification, with only a base switch "S200" currently in use	N/A	EID?	EID=xxxx (see description for details of arguments)
Faults and Status	N/A	13 bytes, numerical	Query only. Unit returns the current fault and status codes for the switch itself, where each location in the string is either 0 for no fault or 1 for faulted, and the positions are: 1 (leftmost) = RM remote comm problem 2/3 = +5v PSU-A under/over 4/5 = +5v PSU-B under/over 6/7 = +12v PSU-A under/over 8/9 = +12v PSU-B under/over 10/11 = -12v PSU-A under/over 12/13 (rightmost) = -12v PSU-B under/over	N/A	FLT?	FLT=xxxxxxxx xxxx (see description for details of arguments)

## 13 CABLE DRAWINGS

**Figure 7** shows the cable required for a simple RS232 connection between a PC serial port and the CRS-200 remote control port. This is needed for Flash upgrading.

The EIA-530 standard pinout (provided on the CRS-200) is becoming more popular in many applications. However, there are still many occasions when, especially for existing RS422/449 and V.35 users, a conversion must be made.

For these situations, **Figure 8** and **Figure 9** show cable drawings for EIA-530 to RS422/449 DCE conversion, and EIA-530 to V.35 DCE conversion.

**Figure 10** shows the cable required to connect the TMI and RMI to the modems.



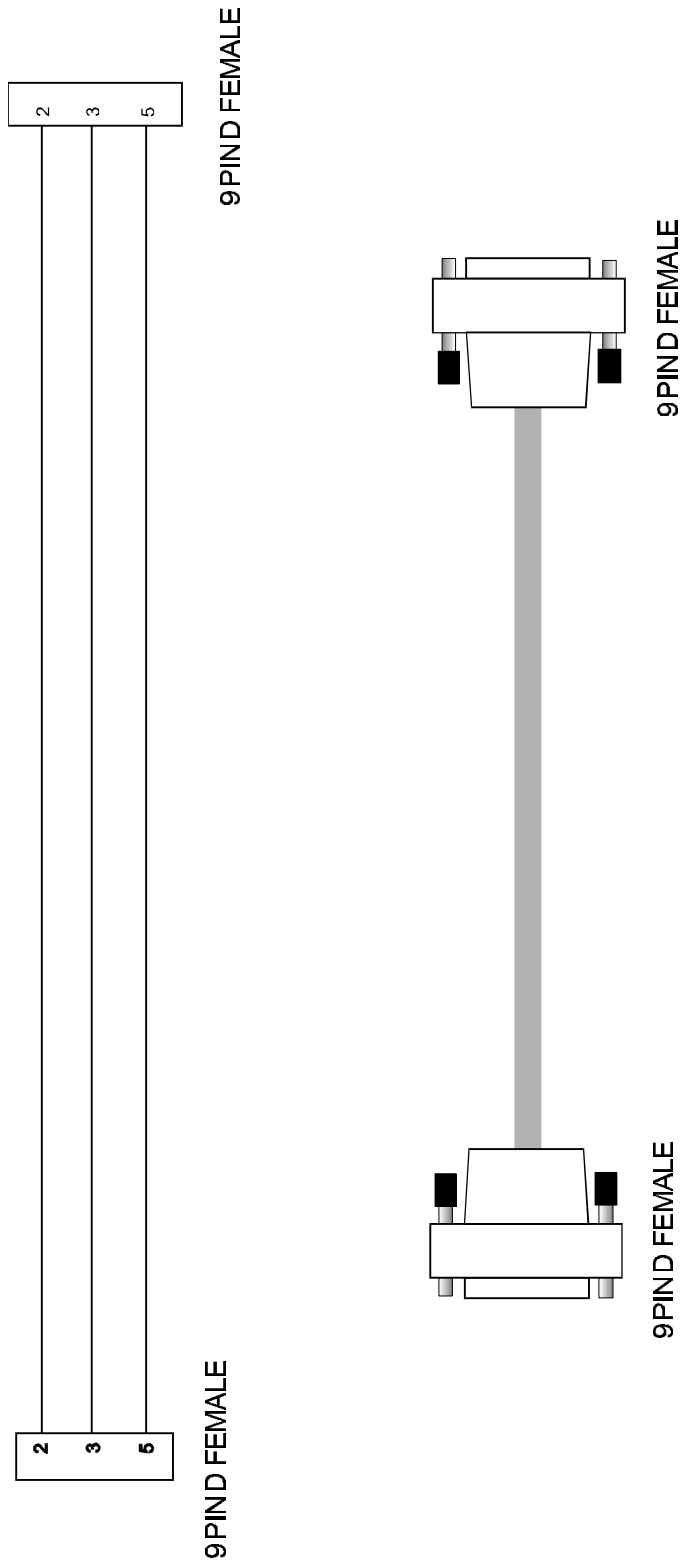
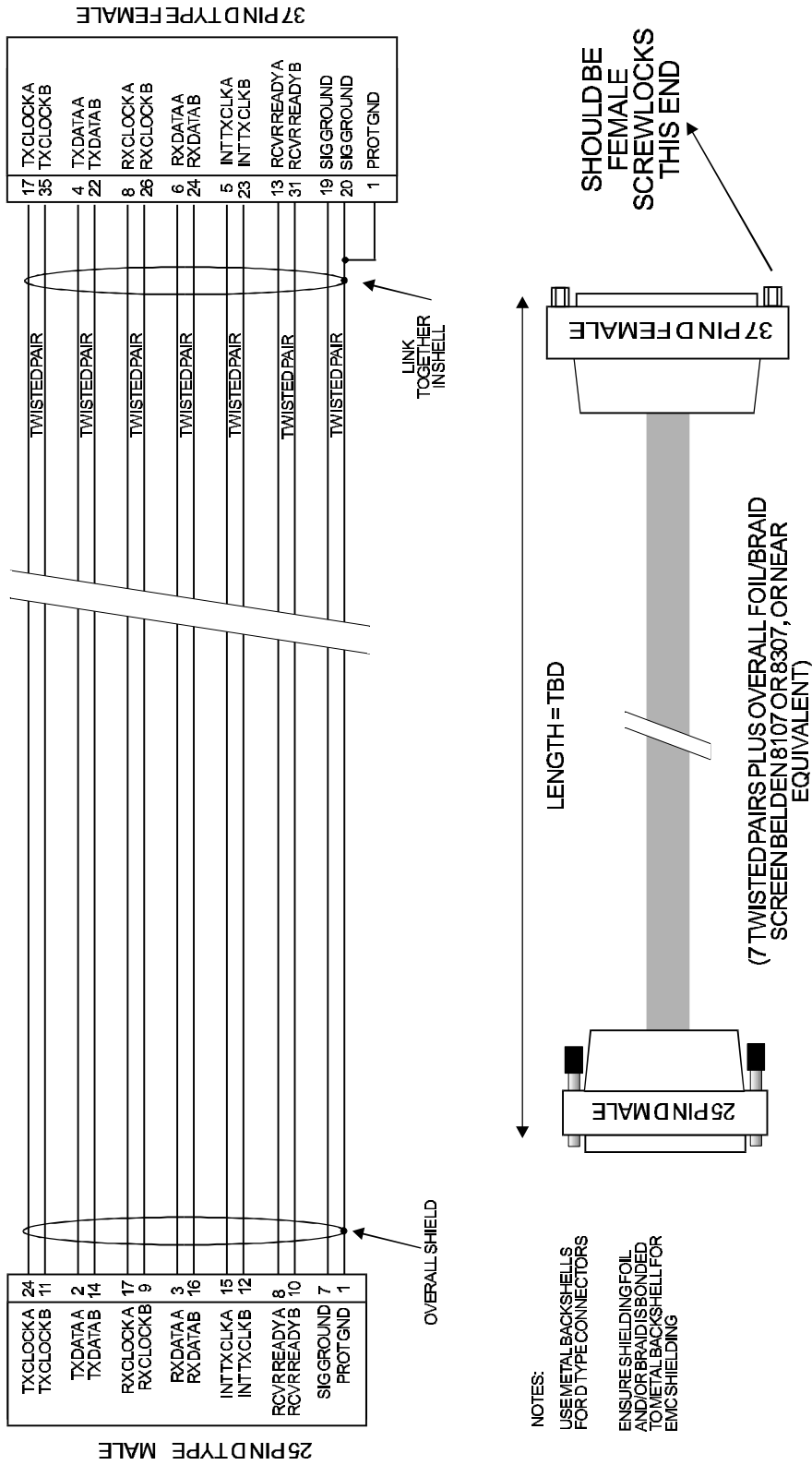

FIGURE 7 PC 9 PIN SERIAL PORT TO CDM-550 RS232 REMOTE CONTROL PORT



NOTES:  
 USE METAL BACKSHELLS FOR D TYPE CONNECTORS  
 ENSURE SHIELDING FOIL AND/OR BRAID IS BONDED TO METAL BACKSHELL FOR EMC SHIELDING

SHOULD BE FEMALE SCREWLOCKS THIS END

FIGURE 8 EIA530 TO RS422/449 DCE CONVERSION CABLE

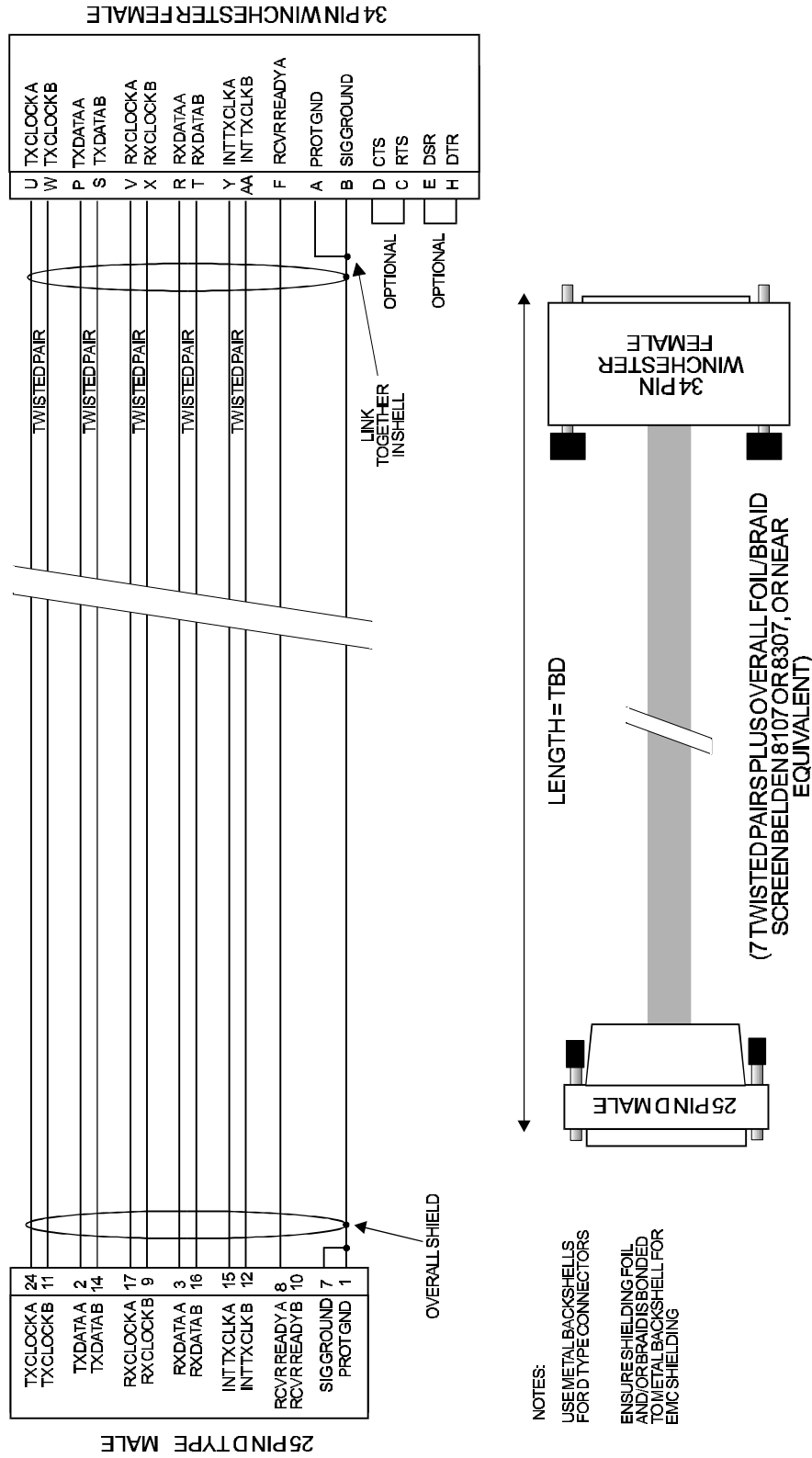

FIGURE 9 EIA530 TO V.35 DCE CONVERSION CABLE

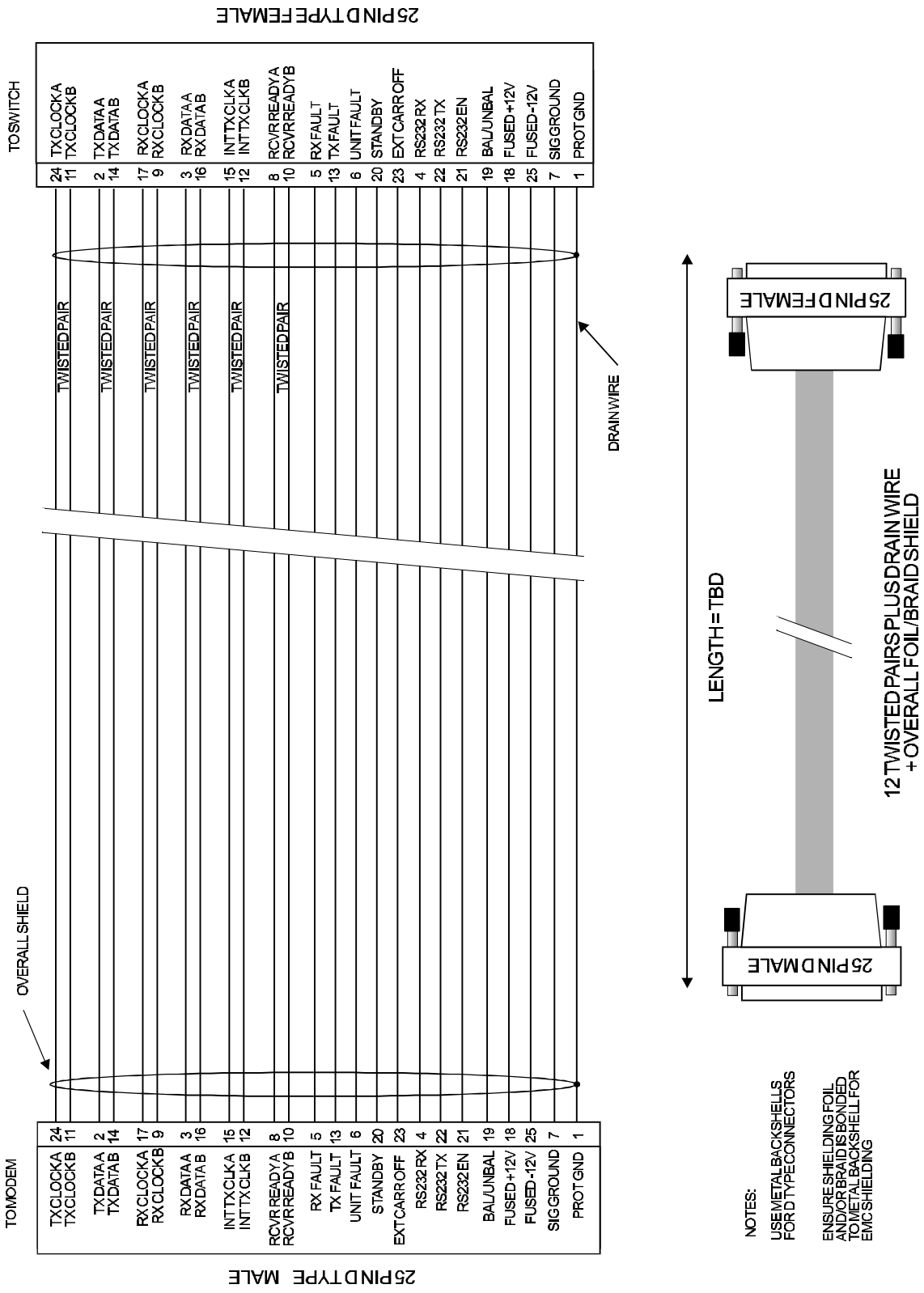

FIGURE 10 SWITCH TO MODEM CABLE