



CIC-20 LVDS to HSSI

Interface Converter
Installation and Operation Manual
(Accessory Product for use only with Comtech EF Data CDM-600 Modems)

Part Number MN/CIC20.IOM
Revision 0
November 6, 2001



CIC-20 LVDS to HSSI

Interface Converter Installation and Operation Manual (Accessory Product for use only with Comtech EF Data CDM-600 Modems)

Comtech EF Data is an ISO 9001
Registered Company.



Part Number MN/CIC20.IOM
REVISION 0
November 6, 2001

CUSTOMER SUPPORT

Contact the Comtech EF Data Customer Support Department for:

- ▶ Product support or training
- ▶ Information on upgrading or returning a product
- ▶ Reporting comments or suggestions concerning manuals

Contact Customer Support using any of the following methods:

Mail: Comtech EF Data
Customer Support Department
2114 West 7th Street
Tempe, Arizona 85281 USA

Email: service@comtechefdata.com

Internet: www.comtechefdata.com

Phone: (480) 333-2200 (Main Comtech EF Data Number)

(480) 333-4357 (Customer Support Desk)

Fax: (480) 333-2161

To return a Comtech EF Data product (in-warranty and out-of-warranty) for repair or replacement:

1. Request a Return Material Authorization (RMA) number from the Comtech EF Data Customer Support Department.
2. Be prepared to supply the Customer Support representative with the model number, serial number, and a description of the problem.
3. To ensure that the product is not damaged during shipping, pack the product in its original shipping carton/packaging.
4. Ship the product back to Comtech EF Data. (Shipping charges should be prepaid.)

For more information regarding the warranty policies, see Warranty Policy, p. ix.

Table of Contents

CHAPTER 1. INTRODUCTION	1
CHAPTER 2. INSTALLATION	3
CHAPTER 3. CONNECTOR PINOUTS	5
3.1 Connector Overview	5
3.2 Overhead Interface Connector (P1)	6
3.3 Data Interface Connector (J1)	7
CHAPTER 4. OPERATION	9
4.1 MODEM CONFIGURATION.....	9
4.2 MODE SELECT.....	9
CHAPTER 5. SUMMARY OF SPECIFICATIONS	11

Figures

Figure 1. CIC-20 Connector Locations	5
Figure 2. SCSI-2 Connectors.....	8
Figure 3. Switch Location.....	9

Tables

Table 1. External Connections.....	5
Table 2. Overhead Interface Connector Pin Assignments	6
Table 3. HSSI Pinout (J1) 50-Pin Mini-D/SCSI-2 Female.....	7

ABOUT THIS MANUAL

This manual provides installation and operation information for the Comtech EF Data CIC-20 LVDS to HSSI Interface Converter. This is a technical document intended for earth station engineers, technicians, and operators responsible for the operation and maintenance of the CIC-20 LVDS to HSSI Interface Converter.

RELATED DOCUMENTS

Comtech EF Data CDM-600 Digital Satellite Modem Installation and Operation Manual

CONVENTIONS AND REFERENCES

CAUTIONS AND WARNINGS



Indicates information critical for proper equipment function.



Indicates a hazardous situation that, if not avoided, may result in minor or moderate injury. CAUTION may also be used to indicate other unsafe practices or risks of property damage.



Indicates a potentially hazardous situation that, if not avoided, could result in death or serious injury.

TRADEMARKS

All product names mentioned in this manual may be trademarks or registered trademarks of their respective companies and are hereby acknowledged.

REPORTING COMMENTS OR SUGGESTIONS CONCERNING THIS MANUAL

Comments and suggestions regarding the content and design of this manual will be appreciated. To submit comments, please contact the Comtech EF Data Customer Support Department.

TELECOMMUNICATIONS TERMINAL EQUIPMENT DIRECTIVE

In accordance with the Telecommunications Terminal Equipment Directive 91/263/EEC, this equipment should not be directly connected to the Public Telecommunications Network.



EMC (ELECTROMAGNETIC COMPATIBILITY)

The CIC-20 LVDS to HSSI Interface Converter has been demonstrated, by independent testing, to comply with the following standards:

Emissions: EN 55022 Class B - Limits and methods of measurement of radio interference characteristics of Information Technology Equipment.

FCC PART 15 CLASS B

Immunity: EN 50082 Part 1 - Generic immunity standard, Part 1: Domestic, commercial and light industrial environment.

In order that the CIC-20 LVDS to HSSI Interface Converter continues to comply with these standards, observe the following instructions:

- ▶ All 'D' type connectors attached to the unit must have back-shells which provide continuous metallic shielding. Cable with a continuous outer shield (either foil or braid, or both) must be used, and the shield must be bonded to the back-shell.
- ▶ The equipment must be operated with its cover on at all times. If it becomes necessary to remove the cover, the user should ensure that the cover is correctly re-fitted before normal operation commences.

SAFETY COMPLIANCE

EN 60950

Applicable testing is routinely performed as a condition of manufacturing on all units to ensure compliance with safety requirements of EN60950.

This equipment meets the Safety of Information Technology Equipment specification as defined in EN60950.

The equipment is rated for operation at +12 volts DC and -12 volts DC. It has a maximum power consumption of 2.0 watts. The power supply current is, in all circumstances, supplied by a single Comtech CDM-600 Modem.

EQUIPMENT CONNECTION

The CIC-20 LVDS to HSSI Interface Converter is designed for operation ONLY with Comtech CDM-600 modems. These modems supply DC operating current (electronically fused and protected) and control signals for the correct functioning of this unit. Connection to other manufacturer's equipment could result in damage to the unit.

ENVIRONMENTAL

The CIC-20 LVDS to HSSI Interface Converter must not be operated in an environment where the unit is exposed to extremes of temperature outside the ambient range 0 to 50⁰C, precipitation, condensation, or humid atmospheres above 95% RH, altitudes (un-pressurised) greater than 2000 meters, excessive dust or vibration, flammable gases, corrosive or explosive atmospheres.

Operation in vehicles or other transportable installations which are equipped to provide a stable environment is permitted. If such vehicles do not provide a stable environment, safety of the equipment to EN60950 may not be guaranteed.



LOW VOLTAGE DIRECTIVE (LVD)

The following information is applicable for the European Low Voltage Directive (EN60950):

<HAR>	Type of power cord required for use in the European Community.
	CAUTION: Double-pole/Neutral Fusing. ACHTUNG: Zweipolige bzw. Neutralleiter-Sicherung.

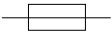
International Symbols:

Symbol	Definition
	Alternating Current.
	Fuse.

Symbol	Definition
	Protective Earth.
	Chassis Ground.

Note: For additional symbols, refer to “Cautions” listed earlier in this preface.

WARRANTY POLICY

This Comtech EF Data product is warranted against defects in material and workmanship for a period of two years from the date of shipment. During the warranty period, Comtech EF Data will, at its option, repair or replace products that prove to be defective.

For equipment under warranty, the customer is responsible for freight to Comtech EF Data and all related custom, taxes, tariffs, insurance, etc. Comtech EF Data is responsible for the freight charges **only** for return of the equipment from the factory to the customer. Comtech EF Data will return the equipment by the same method (i.e., Air, Express, Surface) as the equipment was sent to Comtech EF Data.

LIMITATIONS OF WARRANTY

The foregoing warranty shall not apply to defects resulting from improper installation or maintenance, abuse, unauthorized modification, or operation outside of environmental specifications for the product, or, for damages that occur due to improper repackaging of equipment for return to Comtech EF Data.

No other warranty is expressed or implied. Comtech EF Data specifically disclaims the implied warranties of merchantability and fitness for particular purpose.

EXCLUSIVE REMEDIES

The remedies provided herein are the buyer's sole and exclusive remedies. Comtech EF Data shall not be liable for any direct, indirect, special, incidental, or consequential damages, whether based on contract, tort, or any other legal theory.

DISCLAIMER

Comtech EF Data has reviewed this manual thoroughly in order that it will be an easy-to-use guide to your equipment. All statements, technical information, and recommendations in this manual and in any guides or related documents are believed reliable, but the accuracy and completeness thereof are not guaranteed or warranted, and they are not intended to be, nor should they be understood to be, representations or warranties concerning the products described. Further, Comtech EF Data reserves the right to make changes in the specifications of the products described in this manual at any time without notice and without obligation to notify any person of such changes.

Chapter 1. INTRODUCTION

CIC-20 LVDS to HSSI Interface Converter



While the CDM-600 modem is capable of data rates up to 20 Mbps, its many interfaces do not include the HSSI format.

In order to accommodate the HSSI data formats and overhead, the CIC-20 converter attaches to the rear of the modem at the 25-pin data connectors. No external power is required and all settings are made on the CIC-20 using one switch.

This page has been intentionally left blank.

Chapter 2. INSTALLATION

Perform the following procedural steps:

- 1 Power down the modem before installing the converter.
- 2 Remove the four screws, on the sides, and lift off the cover of the CIC-20.



- 3 The 25-pin female and male D-sub connectors includes four captive screws which can be reached by removing the cover of the CIC-20.

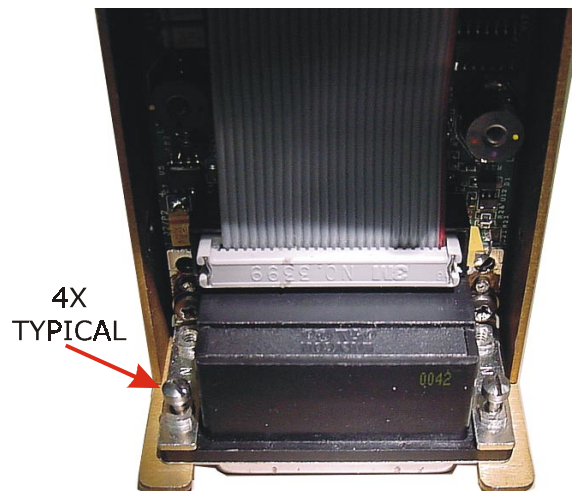

- 4 Attach the CIC-20 to the CDM-600 modem by mating the two pair of 25-pin D-sub connectors together, then tighten the four captive screws.
- 5 Re-attach the cover and replace the four screws. The metal surfaces of the modem and CIC-20 should be flush.

This page has been intentionally left blank

Chapter 3. CONNECTOR PINOUTS

3.1 CONNECTOR OVERVIEW

The rear panel connectors (shown in Table 1) provide all necessary external connections between the modem and other equipment.

Table 1. External Connections

Name	Ref	Connector Type	Function
Overhead	P1	25-pin D (male)	Overhead Data
Data Interface	J1	50-pin, mini-D SCSI-II HSSI (female)	Data Input/Output

Note: To maintain compliance with the European EMC Directive (EN55022, EN50082-1) properly shielded cables are required for data I/O.

**Figure 1.
CIC-20
Connector
Locations**

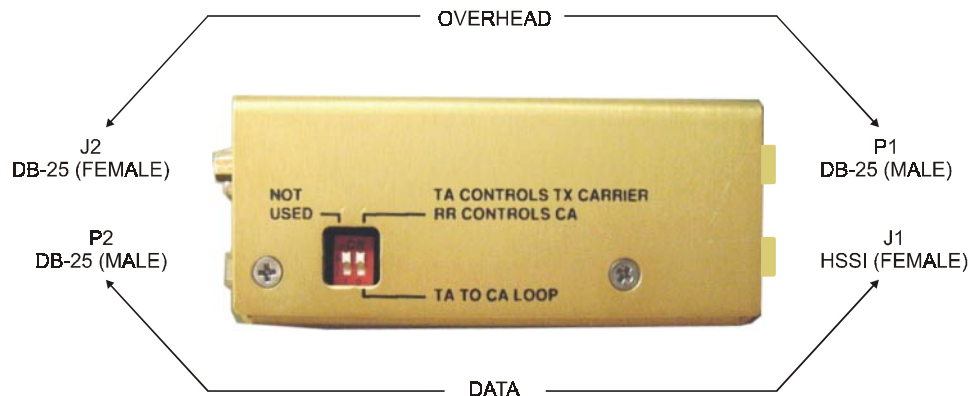

3.2 OVERHEAD INTERFACE CONNECTOR (P1)

The overhead interface connector is a 25-pin D male interface located on the rear panel of the modem. Refer to Table 2 for pin assignments.

Table 2. Overhead Interface Connector Pin Assignments

Pin #	Signal Function	Signal Name	Direction
14	IDR 64 kbps ESC Tx Data +	TX-422DAT-B	In
2	IDR 64 kbps ESC Tx Data -	TX-422DAT-A	In
12	IDR 64 kHz ESC Tx Clock +	TX-422CLK-B	Out
15	IDR 64 kHz ESC Tx Clock -	TX-422CLK-A	Out
11	IDR 1 kHz Tx Octet Clock +	TX-OCT-B	Out
24	IDR 1 kHz Tx Octet Clock -	TX-OCT-A	Out
16	IDR 64 kbps ESC Rx Data +	RX-422DAT-B	Out
3	IDR 64 kbps ESC Rx Data -	RX-422DAT-A	Out
9	IDR 64 kHz ESC Rx Clock +	RX-422CLK-B	Out
17	IDR 64 kHz ESC Rx Clock -	RX-422CLK-A	Out
19	IDR 1 kHz Rx Octet Clock +	RX-OCT-B	Out
4	IDR 1 kHz Rx Octet Clock -	RX-OCT-A	Out
20	Balanced Ext. Ref. Clock +	EXT-CLK-B	In
23	Balanced Ext. Ref. Clock -	EXT-CLK-A	In
13	IBS ESC RS232 Tx Data	TX-232-DATA	In
22	IBS ESC RS232 Tx Clock	TX-232-CLK	Out
8	IBS ESC RS232 Rx Data	RX-232-DATA	Out
10	IBS ESC RS232 Rx Clock	RX-232-CLK	Out
5	IBS Tx High-Rate ESC Data	TX-ASYNC	In
6	IBS Rx High-Rate ESC Data	RX-ASYNC	Out
1	IDR Back Alarm 1 H/W input	BW-IN1	In
18	IDR Back Alarm 2 H/W input	BW-IN2	In
21	IDR Back Alarm 3 H/W input	BW-IN3	In
25	IDR Back Alarm 4 H/W input	BW-IN4	In
7	Signal Ground	Ground	-

3.3 DATA INTERFACE CONNECTOR (J1)

The Data Interface connector is a 50-pin mini D SCSI-II, HSSI type female. Refer to Table 3 for pin assignments.

Table 3. HSSI Pinout (J1) 50-Pin Mini-D/SCSI-2 Female

Signal Function	HSSI Signal	EIA-613 Circuit	Pin # (+, -)	Circuit Direction
Signal Ground	SG	102	1, 26	
Receive Timing	RT	115	2, 27	From DCE
DCE Available	CA	107	3, 28	From DCE
Receive Data	RD	104	4, 29	From DCE
Loopback Circuit C	LC	undefined	5, 30	Not used
Send Timing	ST	114	6, 31	From DCE
Signal Ground	SG	102	7, 32	
DTE Available	TA	108/2	8, 33	To DCE
Terminal Timing	TT	113	9, 34	To DCE
Loopback Circuit A	LA	143	10, 35	Not used
Send Data	SD	103	11, 36	To DCE
Loopback Circuit B	LB	144	12, 37	Not used
Signal Ground	SG	102	13, 38	
Reserved (to DCE)			14,15,17, 18, 39 - 43	Not used
Tx_Carrier_Off_L (Notes 1 and 3)	CO	undefined	16	From DTE
Signal Ground	SG	102	19, 44	
Carrier Detect (lock) (Notes 1 and 2)	CD	undefined	20	From DCE
Mod Fault (Notes 1 and 4)	MF	undefined	21	From DCE
Demod Fault (Notes 1 and 4)	DF	undefined	45	From DCE
Unit Fault (Notes 1 and 4)	UF	undefined	46	From DCE
Reserved (to DTE)			22-23 47-48	Not used
Test Mode	TM	142	24, 49	Not used
Signal Ground	SG	102	25, 50	

Notes:

1. Noted signal function names are non-HSSI defined signals. On Cisco™ routers there is no connection to those pins.
2. TTL - output.
3. TTL or RS232 (active low) input
4. TTL – open collector output.

The HSSI interface uses the type of SCSI-2 connector shown in Figure 2.

Figure 2.
SCSI-2 Connectors

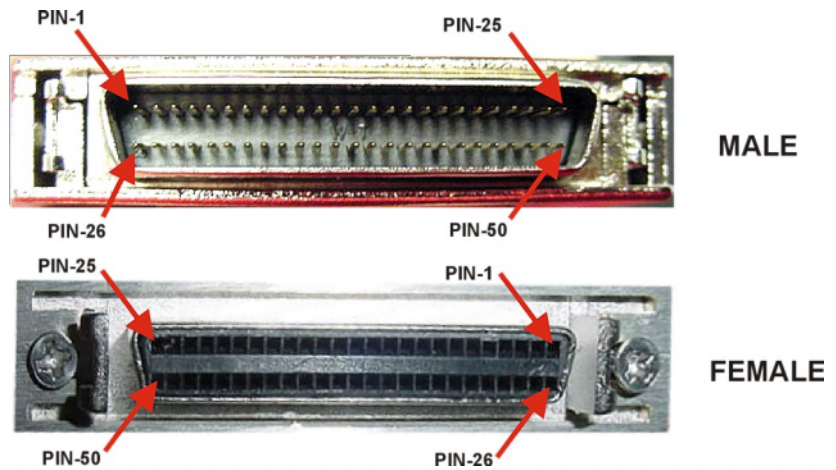

Chapter 4. OPERATION

4.1 MODEM CONFIGURATION

After applying power to the modem, the following configuration changes must be made to the modem in order for it to operate with the CIC-20.

- 1 Program the transmit and receive data rates to what is desired for Tx and Rx.
- 2 Set the data interface type to LVDS. The modem itself operates in this electrical format while the converter translates between LVDS and HSSI.

4.2 MODE SELECT

The dip switch (S2) selects the functionality of the control signals, CA and TA. It can be accessed with a small screwdriver. The OFF (down) position is the default. Switch S1 is not used.

Dip Switch S2	
ON (Up)	TA CONTROLS TX CARRIER RR CONTROLS CA
OFF (Down)	TA TO CA LOOP

**Figure 3.
Switch Location**



This page has been intentionally left blank.

Chapter 5. SUMMARY OF SPECIFICATIONS

Equipment Type	LVDS / HSSI Interface Converter
Modems Supported	Comtech EF Data CDM-600 Digital Satellite Modems
Terrestrial (User) Data Interface:	
Type	HSSI (synchronous serial)
HSSI Signals Supported	RT, RD, ST, TT, SD, TA, CA, Per EIA-612 (10KH ECL)
Other Signals Supported	CD, DF, MF, TX_CARRIER_OFF
Electrical Connector	50-pin mini-D female per EIA-613 (HSSI)
Modem Data Interface	
Type	LVDS, Serial
Data Rate:	2.4 kbps to 20.0 Mbps
Electrical Connector	25-pin D male
Power Requirements	2.0 Watts maximum +12 volts DC -12 volts DC (Power is supplied by the Modem. These power supplies are electronically fused and protected.)
Approvals	'CE' as follows: EN 55022 Class B (Emissions) EN 50082-1 (Immunity) EN 60950 (Safety) FCC Part 15 Class B

This page has intentionally left blank.

METRIC CONVERSIONS

Units of Length

Unit	Centimeter	Inch	Foot	Yard	Mile	Meter	Kilometer	Millimeter
1 centimeter	—	0.3937	0.03281	0.01094	6.214×10^{-6}	0.01	—	—
1 inch	2.540	—	0.08333	0.2778	1.578×10^{-5}	0.254	—	25.4
1 foot	30.480	12.0	—	0.3333	1.893×10^{-4}	0.3048	—	—
1 yard	91.44	36.0	3.0	—	5.679×10^{-4}	0.9144	—	—
1 meter	100.0	39.37	3.281	1.094	6.214×10^{-4}	—	—	—
1 mile	1.609×10^5	6.336×10^4	5.280×10^3	1.760×10^3	—	1.609×10^3	1.609	—
1 mm	—	0.03937	—	—	—	—	—	—
1 kilometer	—	—	—	—	0.621	—	—	—

Temperature Conversions

Unit	° Fahrenheit	° Centigrade
32° Fahrenheit	—	0 (water freezes)
212° Fahrenheit	—	100 (water boils)
-459.6° Fahrenheit	—	273.1 (absolute 0)

Formulas
$C = (F - 32) * 0.555$
$F = (C * 1.8) + 32$

Units of Weight

Unit	Gram	Ounce Avoirdupois	Ounce Troy	Pound Avoir.	Pound Troy	Kilogram
1 gram	—	0.03527	0.03215	0.002205	0.002679	0.001
1 oz. avoir.	28.35	—	0.9115	0.0625	0.07595	0.02835
1 oz. troy	31.10	1.097	—	0.06857	0.08333	0.03110
1 lb. avoir.	453.6	16.0	14.58	—	1.215	0.4536
1 lb. Troy	373.2	13.17	12.0	0.8229	—	0.3732
1 kilogram	1.0×10^3	35.27	32.15	2.205	2.679	—



2114 WEST 7TH STREET TEMPE ARIZONA 85281 USA
480 • 333 • 2200 PHONE
480 • 333 • 2161 FAX